

BERGMANN II C 805 s

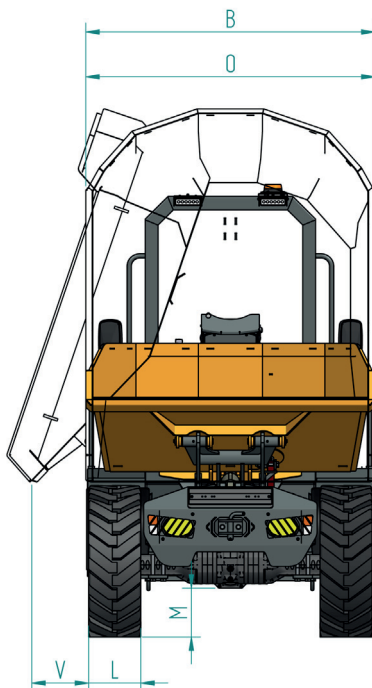

Swivel-tip dumper

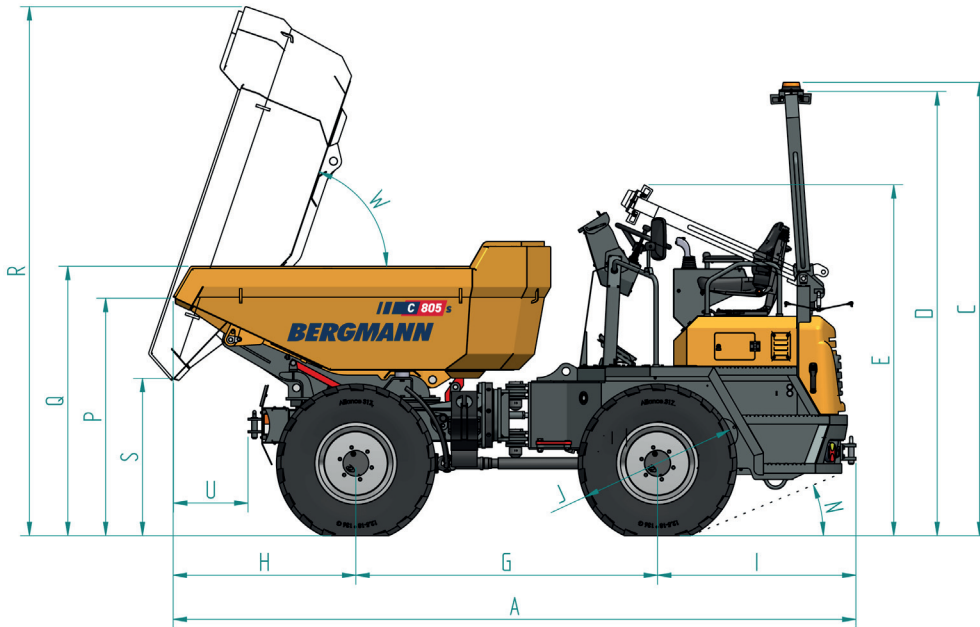

Dimensions

A	4,256 mm	13.96 ft
B	1,800 mm	5.91 ft
C	2,822 mm	9.26 ft
D	2,765 mm	9.07 ft
E	2,184 mm	7.17 ft
G	1,880 mm	6.17 ft
H	1,139 mm	3.74 ft
I	1,237 mm	4.06 ft
J	990 mm	3.25 ft
L	325 mm	1.07 ft
M	305 mm	1 ft
N		22°
O	1,800 mm	5.91 ft
P	1,479 mm	4.85 ft
Q	1,677 mm	5.50 ft
R	3,293 mm	10.80 ft
S	979 mm	3.21 ft
U	464 mm	1.52 ft
V	354 mm	1.16 ft
W		71°

Weight

Empty weight	3,450 kg	7,606 lb
Payload	4,500 kg	9,921 lb

Bucket capacity

Struck	1.9 m ³	2.5 yd ³
Heaped	2.6 m ³	3.4 yd ³

All illustrations, dimensions and weights do not necessarily correspond to the standard equipment and are non-binding with regard to tolerance deviations on component level. We reserve the right to make technical changes.

Technical data

Highlights

- Compact dimensions and flat design
- Excellent power-to-weight ratio (kg/kW)
- Extended field of view on front wheels
- Optimised access to daily maintenance points

Engine

4-cylinder Kubota diesel engine – water-cooled	
Power	53 kW
Rotational speed	1,600 rpm
Emission standard	Stage 5

Transmission

Hydrostatic four-wheel drive with automotive control		
Speed I	0–8 km/h	0–5 mph
Speed II	0–30 km/h	0–18 mph

Steering

Hydraulic articulated steering via priority valve;
articulated joint: 35° left and right

Axles/Brakes

- Front and rear axle rigid, front and rear frame connected by articulated and pendulum joint, pendulum joint: approx. 14° left and right
- Maintenance-free oil-bath multi-disc brake with automatic adjustment in the front axle
- Hydraulically applied locking brake acting over articulated shaft on front and rear axle

Standard tyres

All drive wheels with 12.5/80-18 MPT profile
(more tyre options on request)

Tank capacity

Fuel	50 L
Hydraulic oil	35 L

Electrics

- 12 V electric system with main switch
- Control panel for engine water temperature
- Control lamps for engine oil, park brake, driving display, battery charging control and hydraulic filter
- Display for drive position

Standard equipment

- Hydro sprung seat adjustable
- Instrument panel lowerable and lockable ignition key
- Rear axle with leaf spring suspension
- Lighting system in accordance with German traffic regulations
- Bucket from wear-resistant fine-grain steel
- CE conformity declaration
- Manual/Spare parts list