

P 1000 TOP CLASS

THE LARGEST ALL-TERRAIN ACCESS PLATFORM IN THE WORLD

LIFETIME EXCELLENCE



DIMENSIONS

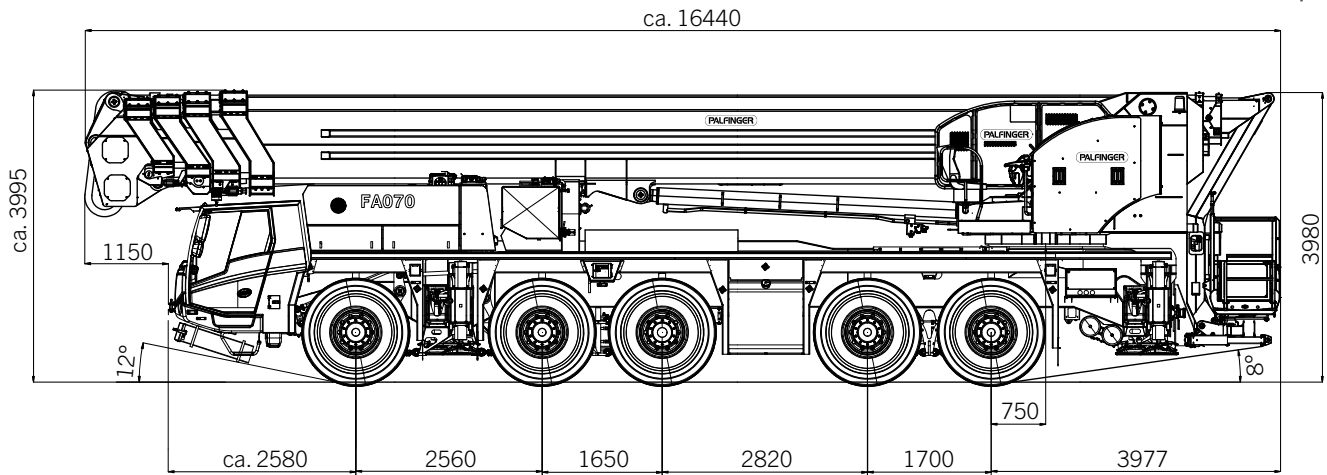

WORKING DIAGRAMS

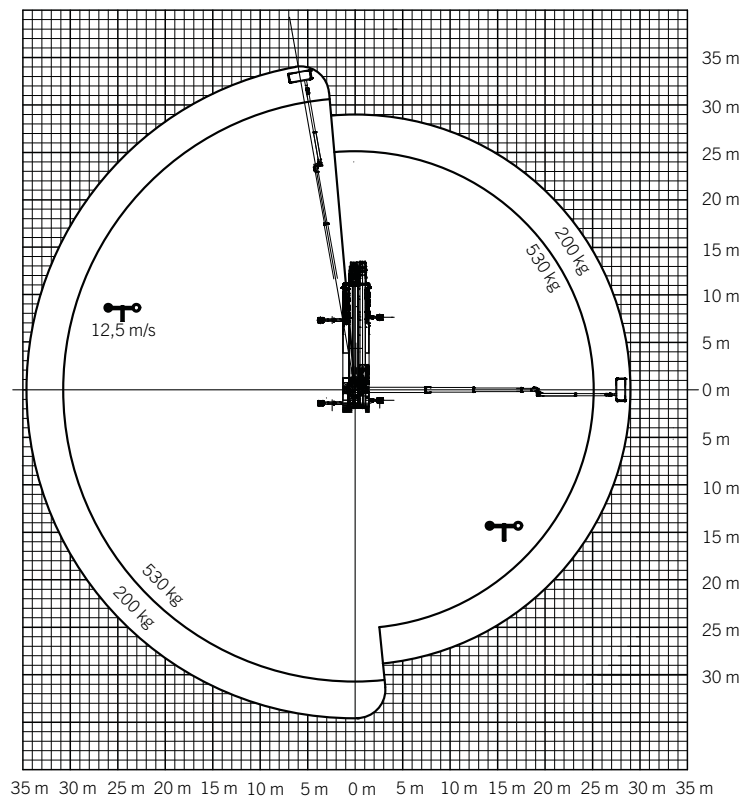
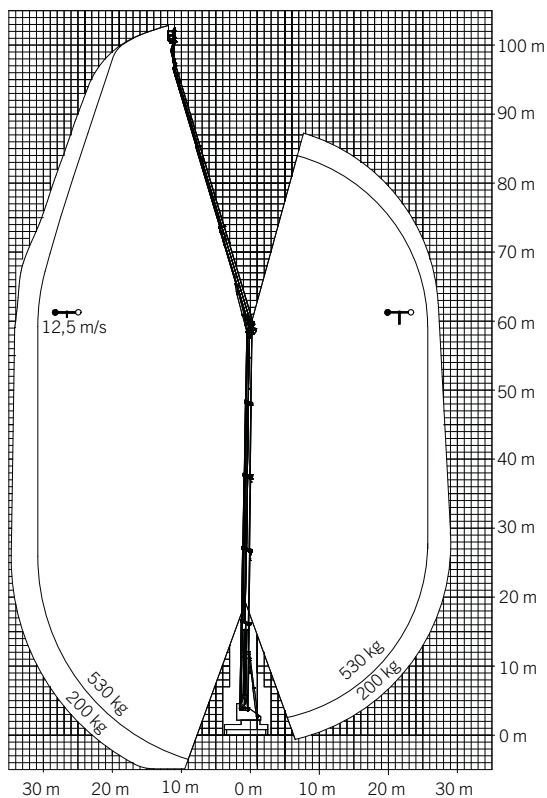

TECHNICAL SPECIFICATIONS

Max. working height	102,5 m
Max. cage bottom height	100,5 m
Max. outreach	35 m
Rotation angle of turnable	endless
Rotation angle of cage	2 x 85°
Max. cage load	530 kg (600 kg*)
Size of cage	3,88/2,15 x 1,05 x 1,10 m
Height in transportposition	< 4 m
Width in transportposition	2,75 m
Overall length	16,44 m
Total weight	60.000 kg

* with heavy duty cage

STANDARD EQUIPMENT

- Maximum stabilizing width of 7,50 m
- Slewing range endless
- Home function
- Automated positioning system
- Safety plates
- Stabilizer control at basis
- Motor Start/Stop in the workman basket
- Synthetic cover on control panel
- 230/400 V CEE outlet in the workman basket
- 5 anchor points to secure safety belt
- Displaceable control panel
- Graphic display
- Reversible slewing direction after panel relocation
- Collision protection for basket and jib boom
- Battery voltage monitoring in the basket



KP-P1000M1+EN

Units shown in the leaflet are partially optional equipped and do not always correspond to the standard version. Country-specific regulations must be observed. Dimensions may vary. Subject to technical changes, errors and translation mistakes.