

Technical sheet :

# **MI 100 D**

---



	Technical characteristics		Metric
1.1	Manufacturer		Manitou
1.2	Model Name		MI 100 D
1.3	Power source		Diesel
1.4	Operator type		Seated
1.5	Max. capacity	Q	10000 kg
1.6	Load centre of gravity	c	600 mm
1.8	Load distance, centre of drive axle to fork	x	713 mm
1.9	Wheelbase	y	2800 mm
	<b>Weight</b>		
2.1	Service weight		14340 kg
2.2	Weight on front axle (laden) / rear axle (laden)		21885 kg / 2455 kg
2.3	Weight on front axle (Unladen) / rear axle (Unladen)		6790 kg / 7550 kg
	<b>Wheels</b>		
3.1	Tyres type		Pneumatic
3.2	Dimensions of front wheels		9.00-20-14PR
3.3	Dimensions of rear wheels		9.00-20-14PR
3.5	Number of front wheels / rear wheels		4 / 2
3.5.2	Number of drive wheels		4
3.6	Front wheel gauge	b10	1628 mm
3.7	Rear wheel gauge	b11	1700 mm
	<b>Dimensions</b>		
4.1	Tilt of Mast Forward (deg) / Backward (deg)	$\alpha / \beta$	6 / 12
4.7	Height of overhead guard (cabin)	h6	2580 mm
4.8	Seat height/stand height	h7	1505 mm
4.12	Height of towing bar (coupling height)	h10	840 mm
4.19	Overall length	l1	5802 mm
4.20	Length to face of forks	l2	4282 mm
4.21	Overall width	b1	2165 mm
4.22	Forks section / width / length	s / e / l	80 mm x 160 mm / 1520 mm
4.23	Fork carriage ISO 2328 (class/form) A/B		5A
4.24	Fork carriage width	b3	2100 mm
4.31	Ground clearance below mast	m1	190 mm
4.32	Ground clearance at centre of wheelbase	m2	339 mm
4.33	Aisle width for 1000 x 1200 pallet widthways	Ast	5995 mm
4.34	Aisle width for 800 x 1200 pallet lengthways	Ast	6134 mm
4.35	Turning radius	Wa	3980 mm
4.36	Internal turning radius (over tyres)	b13	1396 mm
	<b>Performances</b>		
5.1	Travel speed (laden / unladen)		24 km/h / 24.5 km/h
5.2	Lifting speed (laden / unladen)		0.31 m/s / 0.33 m/s
5.3	Lowering speed (laden / unladen)		0.45 m/s / 0.36 m/s
5.5	Drawbar pull (Laden / Unladen)		9430 daN / 3960 daN
5.7	Gradeability (laden)		28 %
5.10	Service brake		Hydraulic
	<b>Engine</b>		
7.1	Engine brand / model		Deutz / TCD 3.6
7.2	Engine power according to ISO 1585		85 kW
7.3	Rated speed		2200 rpm
7.4	Number of cylinders / Capacity of cylinders		4 - 3600 cm <sup>3</sup>
7.5	Fuel consumption according to VDI cycle		12.8 l/h
	<b>Miscellaneous</b>		
8.2	Working hydraulic pressure for attachments		195 Bar
8.3	Oil flow rate for attachments		64 l/min
8.4	Measured/guaranteed mean noise level at the ear of the operator		< 84 dB(A)

## Dimensional drawing

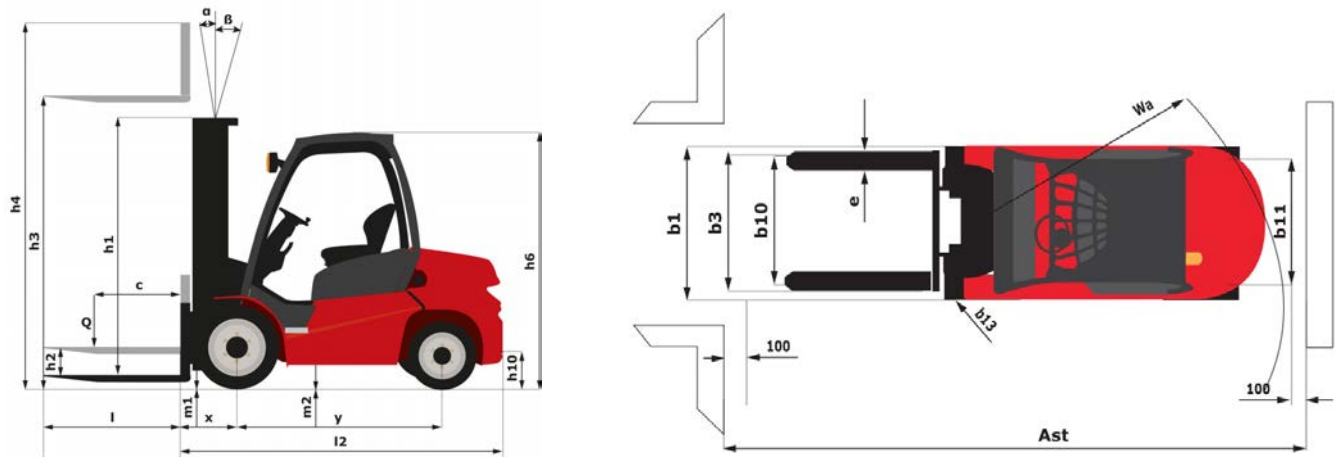

## Characteristics of masts and residual capacities

Full Visibility Duplex		FVD 30	FVD 33	FVD 36	FVD 40	FVD 45	FVD 50
h1 - Height mast lowered *	mm	2850	3000	3150	3350	3650	3900
h2 - Free lift	mm	200	200	200	200	200	200
h3 - Lifting Height	mm	3000	3300	3600	4000	4500	5000
h4 - Height mast extended *	mm	4555	4855	5155	5555	6055	6555
α / β - Mast inclination (front / rear)	°	6 / 12	6 / 12	6 / 12	6 / 12	6 / 6	6 / 6
Height at max capacity	mm	3000	3300	3600	4000	4500	5000
Residual capacity with integrated sideshift (Maximum height & LC = 600 mm)	kg	9600	9600	9600	9600	9600	9600
Residual capacity without attachment (Industrial load chart)	kg	10000	10000	10000	10000	10000	10000
Height at max capacity Fork positioner + DL	mm	3000	3300	3600	4000	4500	5000

Free Lift Triplex		FLT 45	FLT 48	FLT 50	FLT 55	FLT 60
h1 - Height mast lowered *	mm	2850	2950	3050	3200	3350
h2 - Free lift	mm	1305	1405	1505	1655	1805
h3 - Lifting Height	mm	4500	4800	5000	5500	6000
h4 - Height mast extended *	mm	6055	6355	6555	7055	7555
α / β - Mast inclination (front / rear)	°	6 / 6	6 / 6	6 / 6	3 / 6	3 / 6
Height at max capacity	mm	4500	4800	5000	5500	6000
Residual capacity with integrated sideshift (Maximum height & LC = 600 mm)	kg	8100	8100	7800	7300	6600
Residual capacity without attachment (Industrial load chart)	kg	8500	8500	8200	7700	7000
Height at max capacity Fork positioner + DL	mm	4500	4800	5000	5500	6000

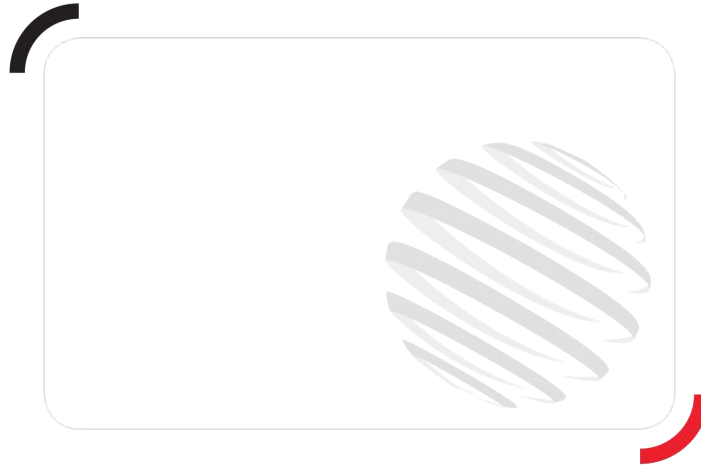

Siège Social  
430 rue de l'Aubinière - 44150 Ancenis Cedex - France  
Tel: +33(0)2 40 09 10 11 - Fax: +33 (0)2 40 09 10 97  
[www.manitou.com](http://www.manitou.com)



This brochure describes versions and configuration options for Manitou products which may be fitted with different equipment. The equipment described in this brochure may be standard, optional or not available depending on version. Manitou reserves the right to change the specifications shown and described at any time and without prior warning. The manufacturer is not liable for the specifications given. For more information, contact your Manitou dealer. Non-contractual document. Product descriptions may differ from actual products. List of specifications is not comprehensive. The logos and visual identity of the company are the property of Manitou and may not be used without authorisation. All rights reserved. The photos and diagrams contained in this brochure are provided for information only.

MANITOU BF SA - Limited company with board of directors - Share capital: 39,668,399 euros - 857 802 508  
RCS Nantes