

Technical sheet :

ME 418



	Technical characteristics		Metric
1.1	Manufacturer		Manitou
1.2	Model Name		ME 418
1.3	Power source		Electric
1.4	Operator type		Seated
1.5	Max. capacity	Q	1800 kg
1.6	Load centre of gravity	c	500 mm
1.8	Load distance, centre of drive axle to fork	x	411 mm
1.9	Wheelbase	y	1380 mm
	Weight		
2.1	Service weight		3070 kg
2.2	Weight on front axle (laden) / rear axle (laden)		4350 kg / 520 kg
2.3	Weight on front axle (Unladen) / rear axle (Unladen)		1400 kg / 1670 kg
	Wheels		
3.1	Tyres type		PPS
3.2	Dimensions of front wheels		21 x 8-9
3.3	Dimensions of rear wheels		5.00-8
3.5	Number of front wheels / rear wheels		2 / 2
3.5.2	Number of drive wheels		2
3.6	Front wheel gauge	b10	938 mm
3.7	Rear wheel gauge	b11	898 mm
	Dimensions		
4.1	Tilt of Mast Forward (deg) / Backward (deg)	α / β	5 / 10
4.7	Height of overhead guard (cabin)	h6	2130 mm
4.8	Seat height/stand height	h7	1045 mm
4.12	Height of towing bar (coupling height)	h10	275 mm
4.19	Overall length	l1	3248 mm
4.20	Length to face of forks	l2	2098 mm
4.21	Overall width	b1	1138 mm
4.22	Forks section / width / length	s / e / l	100 mm x 1150 mm / 35 mm
4.23	Fork carriage ISO 2328 (class/form) A/B		2A
4.24	Fork carriage width	b3	1000 mm
4.31	Ground clearance below mast	m1	100 mm
4.32	Ground clearance at centre of wheelbase	m2	110 mm
4.33	Aisle width for 1000 x 1200 pallet widthways	Ast	3511 mm
4.34	Aisle width for 800 x 1200 pallet lengthways	Ast	3711 mm
4.35	Turning radius	Wa	1900 mm
4.36	Internal turning radius (over tyres)	b13	680 mm
	Performances		
5.1	Travel speed (laden / unladen)		13.5 km/h / 14 km/h
5.2	Lifting speed (laden / unladen)		0.29 m/s / 0.44 m/s
5.3	Lowering speed (laden / unladen)		0.49 m/s / 0.48 m/s
5.5	Drawbar pull (Laden / Unladen)		1200 daN / 1100 daN
5.7	Gradeability (laden / unladen)		12 % / 13 %
5.10	Service brake		Hydraulic
	Engine		
6.1	Drive motor rating S2 60 min		8 kW
6.2	Lift motor rating at S3 15%		8.6 kW
6.3	Battery according to DIN 43531/35/36 A, B, C		DIN43531 A
6.4	Battery / Batteries capacity		48 V / 465 Ah
6.6	Energy consumption		4.6 kW/h
	Miscellaneous		
8.1	Type of drive control		Electronic
8.2	Working hydraulic pressure for attachments		175 Bar
8.3	Oil flow rate for attachments		35 l/min
8.4	Measured/guaranteed mean noise level at the ear of the operator		< 71 dB(A)

Dimensional drawing

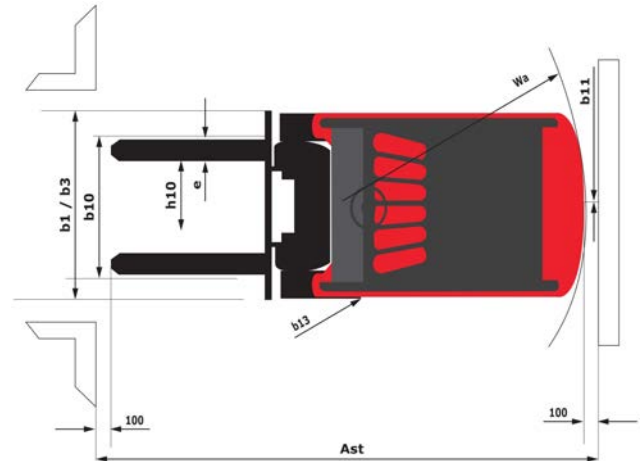
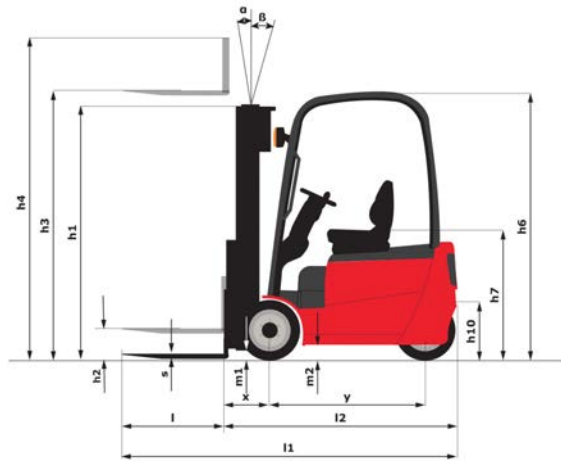

Characteristics of masts and residual capacities

Full Visibility Duplex		FVD 27	FVD 30	FVD 33	FVD 36	FVD 40	FVD 43	FVD 45
h1 - Height mast lowered *	mm	1825	1975	2125	2325	2575	2725	2825
h2 - Free lift	mm	145	145	145	145	145	145	145
h3 - Lifting Height	mm	2700	3000	3300	3600	4000	4300	4500
h4 - Height mast extended *	mm	3265	3565	3865	4165	4565	4865	5065
α / β - Mast inclination (front / rear)	°	5 / 6	5 / 10	5 / 10	5 / 10	5 / 10	5 / 6	5 / 6
Residual capacity with hooked-on side shift (Industrial load chart)	kg	1800	1800	1800	1700	1650	1550	1500
Height at max capacity	mm	2700	3000	3300	3600	4000	4300	
Height at max capacity with integrated sideshift	mm	2700	3000	3300	3600	4000		
Residual capacity without attachment (Industrial load chart)	kg	1800	1800	1800	1800	1800	1700	1650
Residual capacity with integrated side shift (Industrial load chart)	kg	1800	1800	1800	1800	1750	1650	1600

Free Lift Duplex		FLD 27	FLD 30	FLD 33	FLD 36	FLD 40
h1 - Height mast lowered *	mm	1825	1975	2125	2275	2525
h2 - Free lift	mm	1240	1390	1540	1690	1940
h3 - Lifting Height	mm	2700	3000	3300	3600	4000
h4 - Height mast extended *	mm	3295	3595	3895	4195	4595
α / β - Mast inclination (front / rear)	°	5 / 6	5 / 10	5 / 10	5 / 10	5 / 10
Residual capacity with hooked-on side shift (Industrial load chart)	kg	1800	1800	1800	1700	1650
Height at max capacity	mm	2700	3000	3300	3600	4000
Height at max capacity with integrated sideshift	mm	2700	3000	3300	3600	4000
Residual capacity without attachment (Industrial load chart)	kg	1800	1800	1800	1800	1800
Residual capacity with integrated side shift (Industrial load chart)	kg	1800	1800	1800	1800	1750

Free Lift Triplex		FLT 40	FLT 43	FLT 45	FLT 48	FLT 50	FLT 55	FLT 60	FLT 65
h1 - Height mast lowered *	mm	1975	2075	2085	2200	2250	2425	2650	2815
h2 - Free lift	mm	1250	1350	1500	1600	1665	1840	2000	2200
h3 - Lifting Height	mm	4000	4300	4500	4800	5000	5500	6000	6500
h4 - Height mast extended *	mm	4735	5035	5105	5410	5595	6095	6660	7125
α / β - Mast inclination (front / rear)	°	5 / 6	5 / 6	5 / 6	5 / 6	5 / 6	3 / 6	3 / 6	3 / 6
Residual capacity with hooked-on side shift (Industrial load chart)	kg	1550	1550	1500	1450	1400	1250	1150	1000

Free Lift Triplex		FLT 40	FLT 43	FLT 45	FLT 48	FLT 50	FLT 55	FLT 60	FLT 65
Height at max capacity	mm	4000							
Height at max capacity with integrated sideshift	mm	4000							
Residual capacity without attachment (Industrial load chart)	kg	1700	1650	1650	1600	1550	1500	1300	1150
Residual capacity with integrated side shift (Industrial load chart)	kg	1650	1600	1600	1550	1500	1450	1250	1100



Siège Social
430 rue de l'Aubinière - 44150 Ancenis Cedex - France
Tel: +33(0)2 40 09 10 11 - Fax: +33 (0)2 40 09 10 97
www.manitou.com



This brochure describes versions and configuration options for Manitou products which may be fitted with different equipment. The equipment described in this brochure may be standard, optional or not available depending on version. Manitou reserves the right to change the specifications shown and described at any time and without prior warning. The manufacturer is not liable for the specifications given. For more information, contact your Manitou dealer. Non-contractual document. Product descriptions may differ from actual products. List of specifications is not comprehensive. The logos and visual identity of the company are the property of Manitou and may not be used without authorisation. All rights reserved. The photos and diagrams contained in this brochure are provided for information only.

MANITOU BF SA - Limited company with board of directors - Share capital: 39,668,399 euros - 857 802 508
RCS Nantes