

Technical sheet :

MI 15 G



	Technical characteristics		Metric
1.1	Manufacturer		Manitou
1.2	Model Name		MI 15 G
1.3	Power source		Lpg
1.4	Operator type		Seated
1.5	Max. capacity	Q	1500 kg
1.6	Load centre of gravity	c	500 mm
1.8	Load distance, centre of drive axle to fork	x	405 mm
1.9	Wheelbase	y	1420 mm
	Weight		
2.1	Service weight		2710 kg
2.2	Weight on front axle (laden) / rear axle (laden)		3640 kg / 570 kg
2.3	Weight on front axle (Unladen) / rear axle (Unladen)		1230 kg / 1480 kg
	Wheels		
3.1	Tyres type		PPS
3.2	Dimensions of front wheels		6.50-10 10
3.3	Dimensions of rear wheels		5.00-8 8
3.5	Number of front wheels / rear wheels		2 / 2
3.5.2	Number of drive wheels		2
3.6	Front wheel gauge	b10	900 mm
3.7	Rear wheel gauge	b11	920 mm
	Dimensions		
4.1	Tilt of Mast Forward (deg) / Backward (deg)	α / β	6 / 12
4.7	Height of overhead guard (cabin)	h6	2090 mm
4.8	Seat height/stand height	h7	1160 mm
4.12	Height of towing bar (coupling height)	h10	315 mm
4.19	Overall length	l1	3310 mm
4.20	Length to face of forks	l2	2240 mm
4.21	Overall width	b1	1080 mm
4.22	Forks section / width / length	s / e / l	35 mm x 100 mm / 1150 mm
4.23	Fork carriage ISO 2328 (class/form) A/B		FEM 2A
4.24	Fork carriage width	b3	1000 mm
4.31	Ground clearance below mast	m1	115 mm
4.32	Ground clearance at centre of wheelbase	m2	150 mm
4.33	Aisle width for 1000 x 1200 pallet widthways	Ast	3590 mm
4.34	Aisle width for 800 x 1200 pallet lengthways	Ast	3790 mm
4.35	Turning radius	Wa	1985 mm
4.36	Internal turning radius (over tyres)	b13	55 mm
	Performances		
5.1	Travel speed (laden / unladen)		17.5 km/h / 18 km/h
5.2	Lifting speed (laden / unladen)		0.45 m/s / 0.55 m/s
5.3	Lowering speed (laden / unladen)		0.5 m/s / 0.55 m/s
5.5	Drawbar pull (Laden / Unladen)		1460 daN / 770 daN
5.7	Gradeability (laden / unladen)		20 % / 20 %
5.10	Service brake		Hydraulic
	Engine		
6.1	Drive motor rating S2 60 min		29 kW
6.2	Lift motor rating at S3 15%		29 kW
7.1	Engine brand / model		GCT (ex-Nissan) / K21
7.2	Engine power according to ISO 1585		29 kW
7.3	Rated speed		2250 rpm
7.4	Number of cylinders / Capacity of cylinders		4 - 2065 cm ³
7.5	Fuel consumption according to VDI cycle		5.7 l/h
	Miscellaneous		
8.2	Working hydraulic pressure for attachments		160 Bar
8.3	Oil flow rate for attachments		52 l/min
8.4	Measured/guaranteed mean noise level at the ear of the operator		< 81 dB(A)

Dimensional drawing

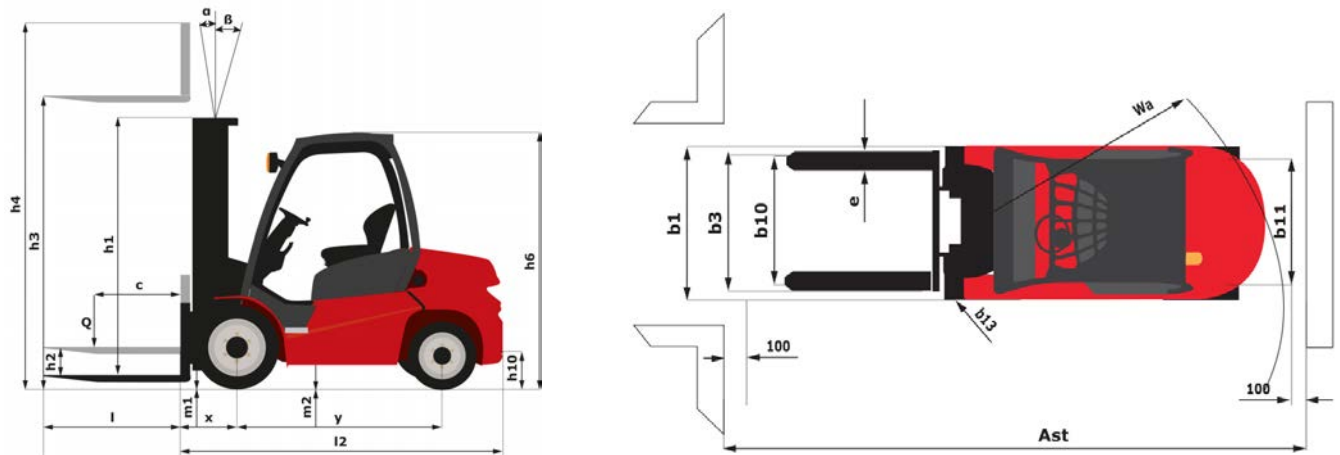

Characteristics of masts and residual capacities

- FVD 33

Full Visibility Duplex		FVD 33	FVD 37	FVD 40
h1 - Height mast lowered *	mm	2145	2395	2595
h2 - Free lift	mm	155	155	155
h3 - Lifting Height	mm	3300	3700	4000
h4 - Height mast extended *	mm	3865	4265	4600
α / β - Mast inclination (front / rear)	°	6 / 12	6 / 12	6 / 12
Residual capacity at max height	kg	1500	1500	1500
Height at max capacity	mm	3300	3700	4000
Height at max capacity with integrated sideshift	mm	3300	3700	4000
Residual capacity without attachment (Industrial load chart)	kg	1500	1500	1500
Residual capacity with integrated side shift (Industrial load chart)	kg	1500	1500	1500

Free Lift Duplex		FLD 33	FLD 37	FLD 40
h1 - Height mast lowered *	mm	2160	2360	2560
h2 - Free lift	mm	1575	1775	1975
h3 - Lifting Height	mm	3300	3700	4000
h4 - Height mast extended *	mm	3885	4285	4585
α / β - Mast inclination (front / rear)	°	6 / 12	6 / 12	6 / 12
Residual capacity at max height	kg	1500	1500	1500
Height at max capacity	mm	3300	3700	4000
Height at max capacity with integrated sideshift	mm	3300	3700	4000
Residual capacity without attachment (Industrial load chart)	kg	1500	1500	1500
Residual capacity with integrated side shift (Industrial load chart)	kg	1500	1500	1500

Free Lift Triplex		FLT 43	FLT 45	FLT 47	FLT 48	FLT 50	FLT 55	FLT 60	FLT 65
h1 - Height mast lowered *	mm	2070	2120	2170	2220	2270	2470	2720	2870
h2 - Free lift	mm	1400	1500	1585	1600	1685	1885	2100	2200
h3 - Lifting Height	mm	4300	4500	4700	4800	5000	5500	6000	6500
h4 - Height mast extended *	mm	4980	5130	5380	5430	5595	6095	6730	7180
α / β - Mast inclination (front / rear)	°	6 / 6	6 / 6	6 / 6	6 / 6	6 / 6	3 / 6	3 / 6	3 / 6

Free Lift Triplex		FLT 43	FLT 45	FLT 47	FLT 48	FLT 50	FLT 55	FLT 60	FLT 65
Residual capacity at max height	kg	1350	1300	1250	1250	1200	950	700	
Height at max capacity	mm	4000							
Residual capacity without attachment (Industrial load chart)	kg	1350	1300	1250	1250	1200	950	700	
Residual capacity with integrated side shift (Industrial load chart)	kg	1350	1300	1150	1150	1100	850	600	

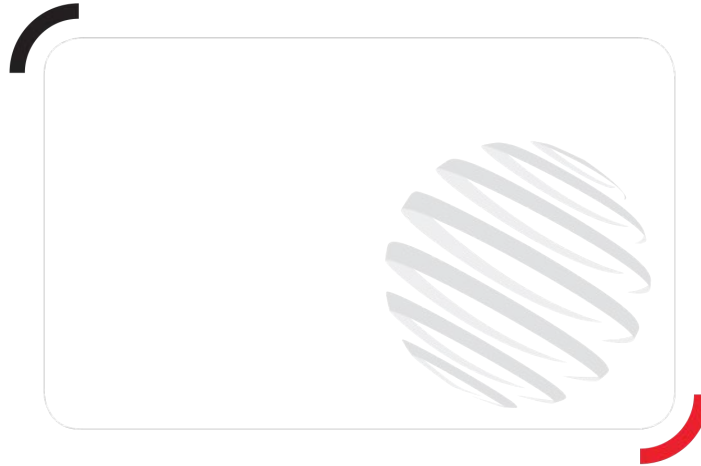

Siège Social
430 rue de l'Aubinière - 44150 Ancenis Cedex - France
Tel: +33(0)2 40 09 10 11 - Fax: +33 (0)2 40 09 10 97
www.manitou.com



This brochure describes versions and configuration options for Manitou products which may be fitted with different equipment. The equipment described in this brochure may be standard, optional or not available depending on version. Manitou reserves the right to change the specifications shown and described at any time and without prior warning. The manufacturer is not liable for the specifications given. For more information, contact your Manitou dealer. Non-contractual document. Product descriptions may differ from actual products. List of specifications is not comprehensive. The logos and visual identity of the company are the property of Manitou and may not be used without authorisation. All rights reserved. The photos and diagrams contained in this brochure are provided for information only.

MANITOU BF SA - Limited company with board of directors - Share capital: 39,668,399 euros - 857 802 508
RCS Nantes