

8155

Wheel Loaders 1.05 - 1.80 m³



KRAMER
on the safe side



The new flagship from Kramer

The new flagship from Kramer, the 8155, consistently puts the customers' needs first. It impresses with sophisticated details and technical innovations, such as the 7-inch display with integrated rearview camera or the air conditioning and automatic bucket return. The cabin ergonomics ensure efficient work and the high horsepower engine provides the necessary power. The 8155 has a bucket tipping load of 6,100 kg, a stacking payload of 4,200 kg and all of this with a low operating weight of just 9,850 kg (varies depending on options).

- The Deutz TCD 3.6 engine drives the wheel loader with 100 kW and meets exhaust emission level V. The Deutz TCD 4.1 engine with 115 kW offers even more power.
- Comfortable working area: The cabin is characterised by ergonomically-arranged operator's controls. The fully glazed cabin allows for an unimpeded view of the quickhitch plate and the entire machine environment.
- EU-wide tractor approval and ball hitch with 1 tonne supporting load: The 8155 can be perfectly used as a tractor. All common ball hitch systems are available.
- An optionally extended loader unit offers lift heights of up to 4.20 metres with a perfect view of the

attachment at the same time.

- A variety of options in the rear make the loader the perfect all-rounder: among other things different hydraulic control circuits, electrical outlet, DIN signal socket and a pneumatic and hydraulic brake.

8155 Technical specifications

	8155	8155L (extended loader unit)
Operating data		
Bucket capacity Standard bucket m ³	1.55	1.35
Operating weight (optionsabhängig) kg	9,850	10,250
Engine / Motor		
Engine / Motor manufacturer	Deutz TCD 3.6	Deutz TCD 3.6
Engine performance (standard) kW	100	100
Engine performance (option) Deutz TCD 4.1 kW	115	115
Emission standards stage (standard)	V	V
Power transmission		
Traction drive	Automotive continuously variable, hydrostatic axial piston drive	Automotive continuously variable, hydrostatic axial piston drive
Travel speed km/h	20	20
Travel speed (Option) km/h	30	30
Driving speed (option) km/h	40	40
Standard tires	500/70R24	500/70R24
Differential lock	100% VA+HA	100% VA+HA
Max. steering angle °	2x40	2x40
Steering and operating hydraulics		
Max. pump discharge capacity l/min	150	150
Max. pump pressure bar	250	250
Max. Powerflow discharge capacity l/min	180	180
Kinematics		
Design system	TPV kinematics	P-kinematics
Tipping load (standard bucket) kg	6,100	5,600
Payload (Stapelnutzlast S=1,25) kg	4,200	3,900
Tilt-in angle °	45	45
Tip-out angle °	45	45
Filling capacities		
Fuel tank l	140	140
Hydraulic oil tank l	125	125
DEF tank l	12	12
Sound emission		
Measured value dB(A)	101	101
Guaranteed value dB(A)	102	102
Noise level at the driver's ear dB(A)	70	70
Vibrations		
Total vibrations value of the upper body extremities	< 2.5	< 2.5

	8155	8155L (extended loader unit)
Highest effective value of weighted acceleration for the body	< 0.5	< 0.5

8155 Dimensions

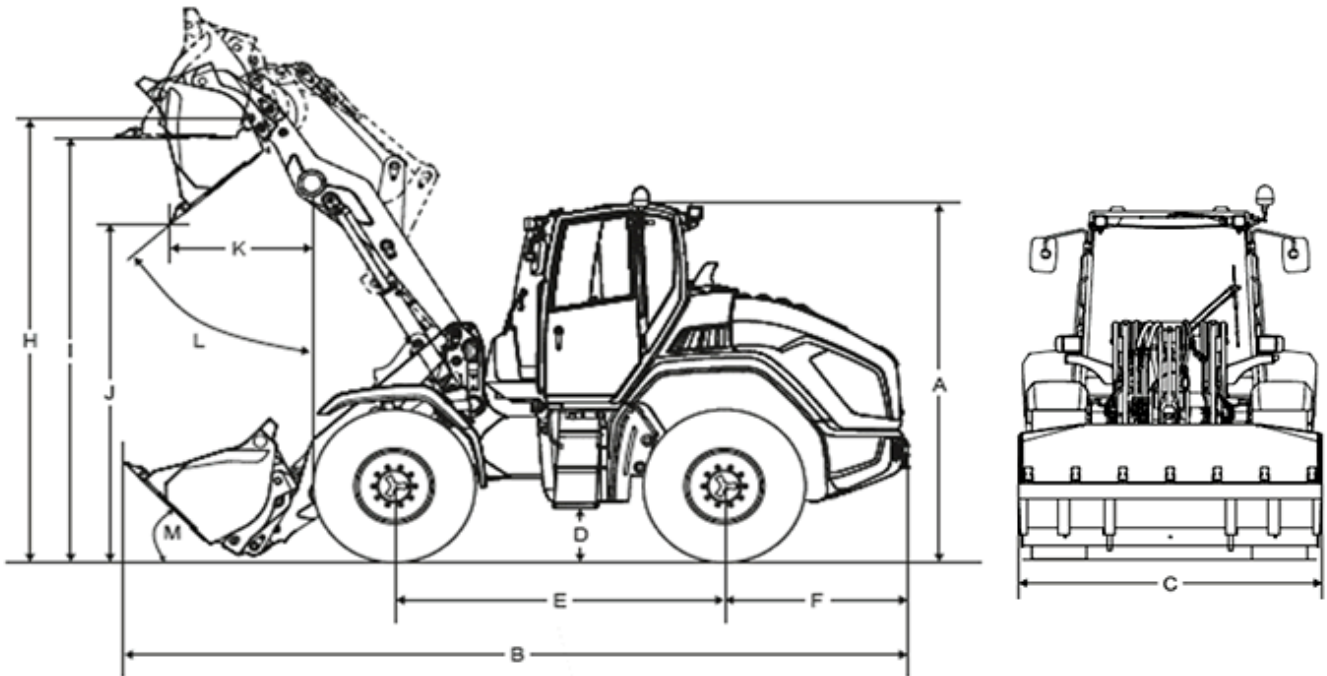

		8155 - standard loader unit	8155L - Extended loader unit
A	Height	3,010 mm	3,010 mm
B	Length	6,450 mm	7,040 mm
C	Width	2,500 mm	2,500 mm
D	Ground clearance	445 mm	445 mm
E	Wheelbase	2,620 mm	2,620 mm
F	Center of rear axle to end of vehicle	1,520 mm	1,520 mm
H	Bucket pivot point	3,760 mm	4,200 mm
I	Overhead loading height	3,520 mm	3,950 mm
J	Dumping height	2,725 mm	3,165 mm
K	Dump reach	1,085 mm	1,275 mm
	Stack height	3,605 mm	4,055 mm
	Turning radius (standard tyres)	3,865 mm	3,865 mm

Please note: that product availability can vary from country to country. It is possible that information / products may not be available in your country. More detailed information on engine power can be found in the operator's manual; the stated power may vary due to specific operating conditions. Subject to alterations and errors excepted. Applicable also to illustrations.

Copyright © 2021 Kramer-Werke GmbH.