

## 10.2 Overall dimensions

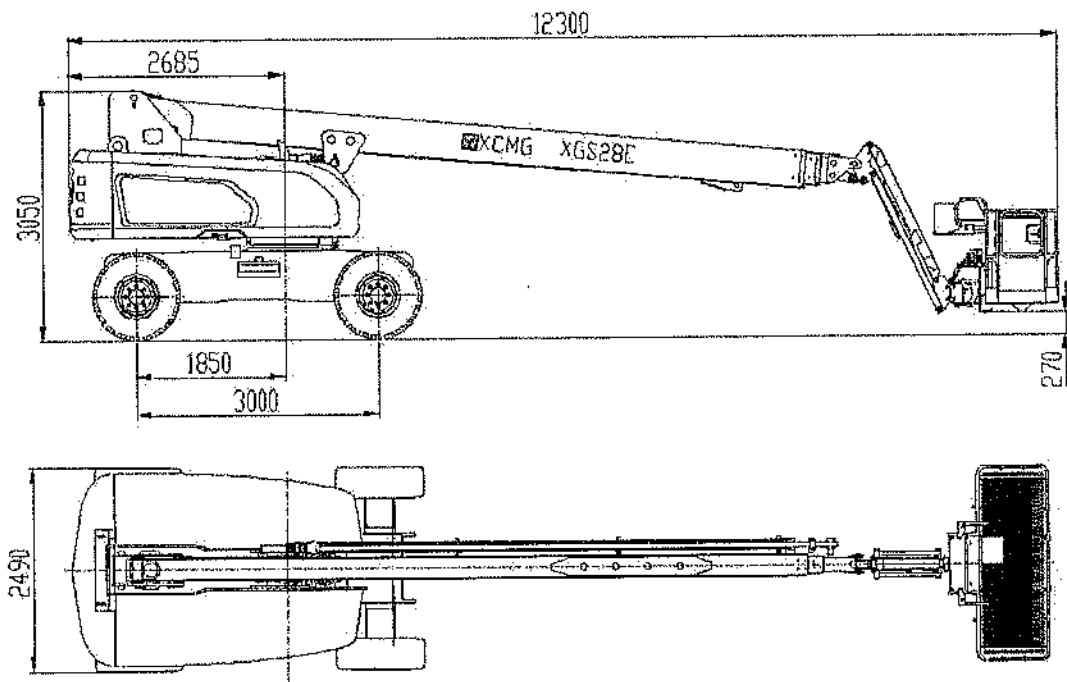

Fig. 10-1: Overview of dimensions

## 10.3 Main parameters

Table 10-1: Main parameters

Equipment height	3.05 m
Equipment length	12.3 m
Equipment width	2.49 m
Wheelbase	3.00 m
Platform height	26.2 m
Tail rotation	1.60 m
Maximum workload	
Unlimited	300 kg
Limited	460 kg
Maximum driving slope	40%
Maximum driving side slope	8°

Ground bearing pressure	8.5 kg/cm <sup>2</sup>
Maximum driving speed	
Collection status	6.1 km/h
Elevated status	1.1 km/h
Maximum main hydraulic system pressure	4500 psi
Maximum wind speed	12.5 m/s
Maximum hand thrust	400 N
Turning radius	6.7 m
Total weight of equipment	18300 kg
Turntable rotation	360°
Fuel tank	180 L
Hydraulic oil tank	129 L
Engine oil capacity	
Cooling system	151 L
Crankcase	9-10 L
Electrical system voltage	12 V

## 10.4 Emissions

### 10.4.1 Noise emissions

The sound emissions of the machine have been measured following the EC Sound Emission Directive (For Outdoor Machinery) 2000/14/EC.

Sound pressure at operators' ear as well as vibration values are in line with the requirements of the EC Machinery Directive 2006/42/EC.

### **⚠ CAUTION!**

- Working in close the machine noise levels may exceed 85 dB(A).
- Wear personal noise protection