



MT15n TIPPER

MT15n TIPPER

Made in Belgium

TECHNICAL DATA

Homologation	N1
Seats	2
Speed	Up to 70 km/h *
WLTP	Up to 132 km *
Turning radius	4,5 m
Weight chassis-cabin	886 kg
Towing capacity	565 - 2000 kg **
Brakes front & rear	Discs
Suspension front & rear	Coiled springs
Vehicle warranty	2 years

ELECTRICAL DATA

Motor type	Three phase asynchronous
Motor power	12 kW
Motor torque	120 Nm
Battery type	LiFePO4
Battery capacity	14,4 kWh
Battery warranty	5 years
Charging	16A 230V

DIMENSIONS

A - Total length	3655 mm
B - Total height	1990 mm
C - Cabin width	1390 mm
D - Cabin height	1990 mm
E - Wheel base	2040 mm
F - Front overhang	1065 mm
G - Rear overhang	550 mm
H - Length tipper	2150 mm
I - Height tipper	1350 mm
J - Width tipper	1450 mm

ADDITIONAL CHARACTERISTICS

Load capacity	779 kg
Internal length tipper	1950 mm
Internal width tipper	1380 mm

* depending on the chosen transmission

** depending on local legislation

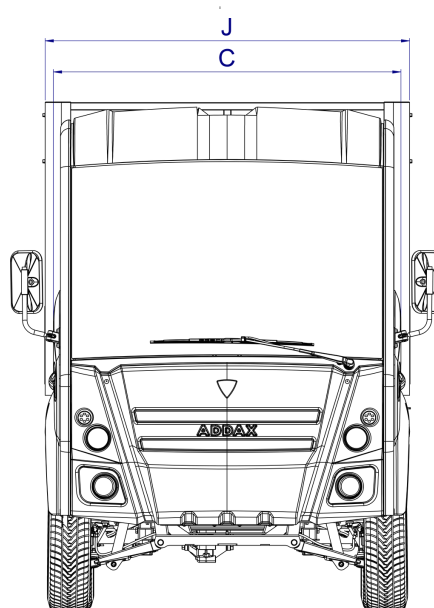
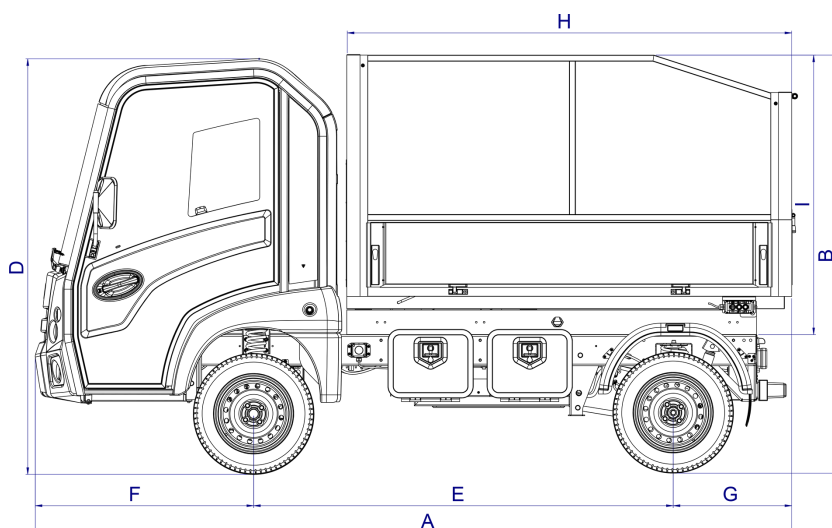
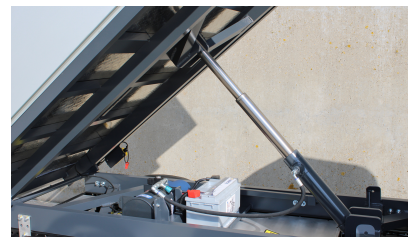
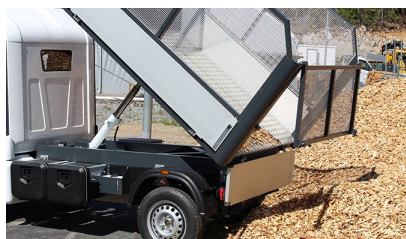

Addax Motors - sales@addaxmotors.com - +32 56 36 50 05 - www.addaxmotors.com

This marketing support presents the models, equipment features and configuration possibilities of Addax electric utility cars. All the characteristics of this document are given as an indication. Addax Motors reserves the right to modify them without notice. Visuals may include standard or optional equipment and accessories depending on the country of sale. Technical specifications correspond to standard versions which may differ according to the country of sale. Please check with your dealer for any local specifications.