

HTH27.11	LIFT CAPACITY	27.000 Kg at 1.200 mm load center		
	MAXIMUM LIFTING EIGHT	10,85 m		
	MAXIMUM REACH	6,60 m		
	FORKS	Fork carriage with forks positioner device 2.000 mm width Forks 300 x 115 x 2.400 mm		
	CAB	FOPS-ROPS tested hermetic cab with protectors		
		Front, rear and upper wiper		
		Headlights for road circulation, flashing beacon		
		Rear view mirrors		
	CONTROLS	Heating - Air conditioning		
		Multi-function electro proportional joystick		
	BRAKE SYSTEM	Hydraulic servo-assisted multidisc brake in oil bath on both axles, with double circuit		
		Negative parking brake		
	ENGINE	Mercedes OM 924 LA Euro 4 Interim	Mercedes OM 924 LA Euro 3A	
		Turbo intercooler	Turbo intercooler	
4 cylinders / 4.800 cm ³		4 cylinders / 4.800 cm ³		
Power 204 HP – 150 kW		Power 196 HP – 145 kW		
Max rpm = 2.200		Max rpm = 2.200		
Max torque 800 Nm at 1.200rpm		Max torque 705 Nm at 1.200 rpm		
Electronic injection (single pump each injector)		Electronic injection (single pump each injector)		
intercooler cooling system		Liquid + intercooler cooling system		
AXLES	Heavy Duty with 2-stage epicyclic reduction			
	One steering cylinders each axle			
	Levelling correction front axle at + 5° on the right and + 5° on the left			
	3 types of steering: - with front steering - with round steer - with crab steering			
PERFORMANCE	Tilting rear axle			
	Max. travel speed: 25 km/h			
	Drawbar pull: 180 kN			
	Gradeability: 30%			
WEIGHTS	Turning radius (end of forks): 9.150 mm			
	Total unladen: 35.500 kg			
	Front axle unladen (boom retracted and lowered): 12.700 kg			
	Rear axle unladen (boom retracted and lowered): 22.800 kg			
TRANSMISSION	Rexroth hydrostatics			
	Variable displacement hydrostatic pump 110 cc with electronic control			
	One variable displacement hydrostatic motor 170 cc			
	Hydraulic gearbox with 2 speeds forward / reverse			
HYDRAULIC CIRCUIT	Differential hydraulic locking			
	Load sensing piston pump 75 cc 165 l/min			
	Circuit at 350 bar			
	Rexroth Proportional hydraulic distributor			
TANKS CAPACITIES	Suction and return line filters			
	High pressure flexible hoses			
	Engine oil = 16 l	Engine oil = 16 l		
	cooling liquid = 25 l	cooling liquid = 25 l		
TYRES DIMENSIONS	Ad Blue = 40 l			
	Hydraulic oil tank = 300 l	Hydraulic oil tank = 300 l		
	Fuel tank = 300 l	Fuel tank = 300 l		
SAFETY	26,5 - R25 ** two each axle, driving and steering			
	Electronic safety system which controls the load with definition of the lifted load, radius and comparison with the diagrams stored.			
	Block of aggravating movements of the load.			
	Safety valves on cylinders			

The data in this brochure are informative and subject to change without notice



Magni Telescopic Handlers srl
Via Magellano, 22 - 41013 Castelfranco Emilia, Modena, Italia
Tel: +39 059 8630811 - Fax: +39 059 8638012
commerciale@magnith.com - www.magnith.com



Maximum lift capacity: 27 t at 1.200 mm load center
Maximum lifting height: 10,85 m
Maximum reach: 6,60 m
Mercedes engine: 150 KW - 204 HP
Electronically controlled hydrostatic transmission



HTH27.11

Full visibility cab MAGNI patented design



Pressurized cab ISO 10.263
 Standard air conditioning and heating
 Touch screen display with joystick control system

HTH27.11

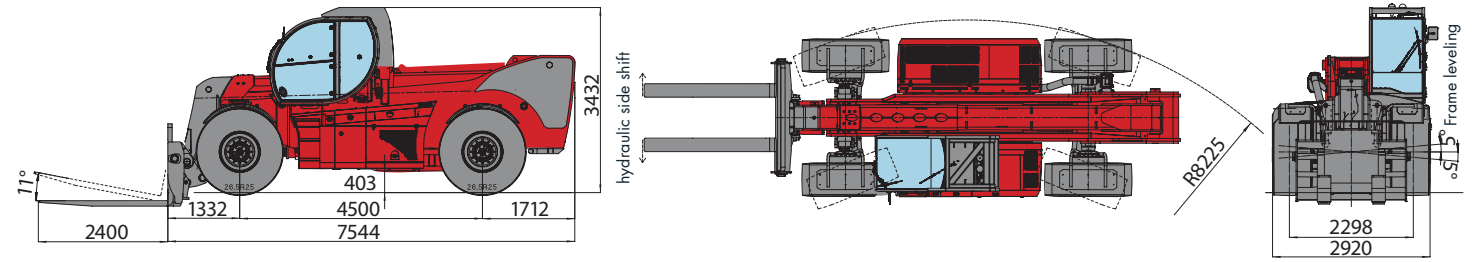

Load chart forcarriage with forks positioner

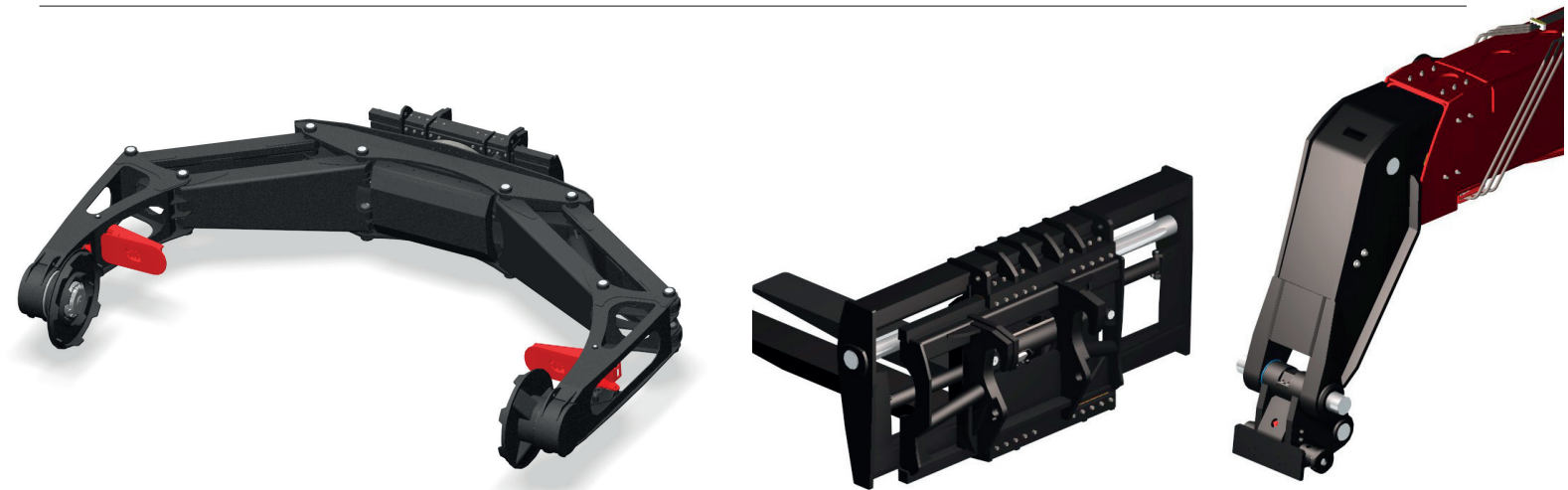
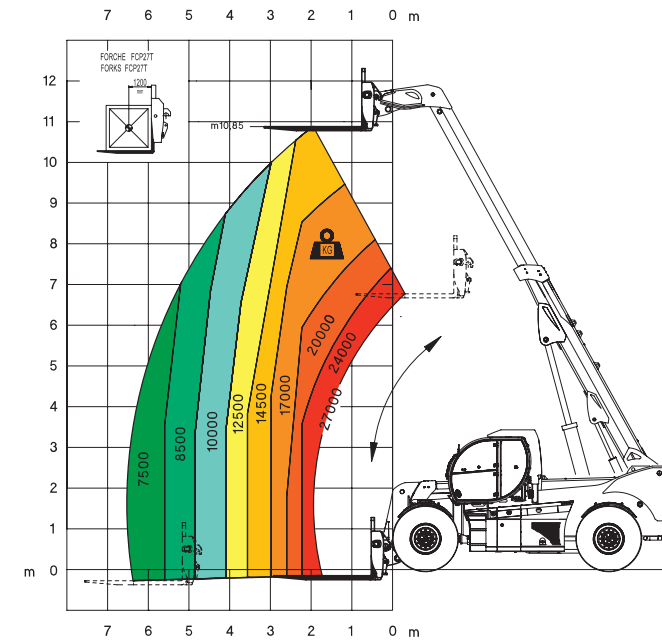

From the left:

- Travelling mode screen
- Load Moment Indicator screen
- Air conditioning management screen

Clamp for wheels handling, with a capacity up to 16.000 kg from 24 to 63 inches .

- MAGNI patented quick fit of the attachment
- Attachments automatic recognition RFID system

