

# Sprint



MADE IN ITALY



A92.6



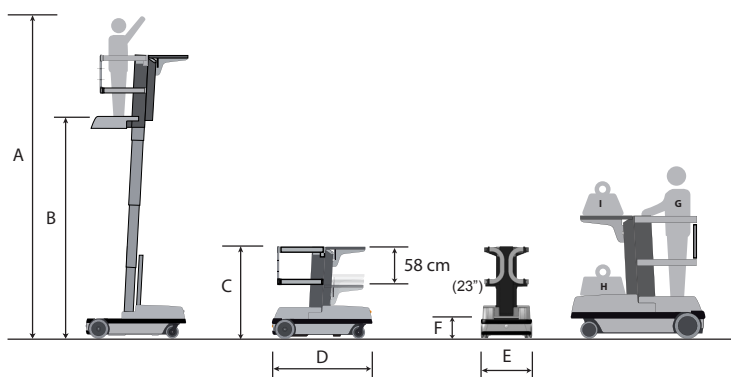

Material tray is electrically operated by a button in the upper control box

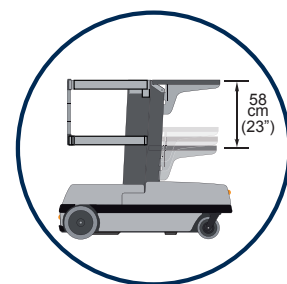

TECHNICAL DATA	METRIC		US
Max. working Height	mm 5350	A	17'6"
Max Platform Height (Upright fully extended)	mm 3350	B	11'
Height Stowed	mm 1441	C	56.7"
Length Stowed	mm 1500	D	59.05"
Width	mm 808	E	31.8"
Platform Entrance Height	mm 356	F	14"
Occupants	1		1
Unit Gross Weight	680 kg		1497 Lbs
Drive Speed stowed	95 mt/min		3.54 mph
Drive Speed raised	30 mt/min		1.1 mph
Max Gradeability	35%		35%
Raise/Lower Speed	18/18 sec		18/18 sec
Turning Radius Outside	1450		57'
Driving System	Two-Handed Proportional		
Tire	Solid Rubber Non Marking		
Tilt Sensor Cut Out	Standard		
Turning Radius Inside	Zero		
<b>CAPACITIES</b>			
Operator's bay capacity	130Kg	G	286 Lbs
Transport hood tray capacity	113 Kg	H	248.9 Lbs
Materials tray capacity	90 Kg	I	198.2 Lbs
<b>POWER</b>			
Batteries	N 04, 6V 245 Ah 20-Hr Rate		
Power	24 V c.c.		
Load network power	110/220 V c.a.		
Autonomy (On one charge)	km 30		18.6 Miles



Loading platform at maximum height corresponds to the column. It is very easy to place even heavy packages using the column as the setting base and letting it slide into the material tray

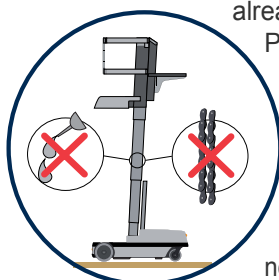

The revolutionary raising system already created by BRAVI PLATFORMS for its mobile platform models is a radical change for this business segment. The column in special extruded aluminum alloy is completely without any need of maintenance.

- No more chains to be inspected every year
- No more grease on the mast
- No maintenance required



Futuristic canopy design, now available also in carbon.

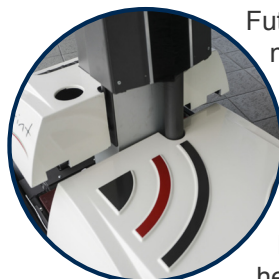

Completely sealed to enhance protection against shocks and damages caused by debris falling from height.



Acceleration of forward/backward movement is proportional and positioned near the basket raising and lowering button, to enable these movements even during forward movement. All the functions are operable without having to move the hand from the accelerator, for maximum operator comfort

Safety position with double sensor pedal and left hand sensor allow activation of the functions. These safety devices serve to guarantee the stable position of the operator, with both hands on the controls before these become activated



More than 30Km ( 18.5 Miles) on one battery charge!