

Masted  
trucks

■ **MC 30**

## A reliable, productive yard truck

- Capacity 3000 kg
- Lifting height 3 m to 7 m





 **MANITOU**

## MC 30

 **Load capacity** .....3000 kg  
At 500 mm load center

 **Standard lifting height** .....3.70 m  
Speed unladen/laden (m/s)  
Lifting .....0.57/0.54  
Lowering.....0.48/0.50

 **Tyres**  
Front.....14.5 R 20 MPT 80  
Tubeless 18 PR 143 G/J  
Rear .....10 R 17.5 134 M G 291

 **Forks (mm)**  
Length .....1200  
Width x thickness.....125x40

 **Brakes hydraulically operated oil-immersed multidiscs**

 **PERKINS engine**  
Type .....1104C 44  
Capacity .....4 cyl. 4400 cm<sup>3</sup>  
Rated speed.....2200 tr/mn  
Power at 2300 t/mn.....61,5 Kw (84 HP)  
(ISO/TR 14396)  
Maximum torque .....302 Nm at 1400 tr/mn  
Direct injection  
Water cooling

 **Transmission**.....Torque convertor  
Electro hydraulic reversing shift  
4 speeds forward and reverse  
Maximum travel speed .....24 km/h  
Hydraulic differential lock

 **Hydraulics**  
Main pump  
Gear type .....185 bar/89 l./mn  
Flow divider with priority to steering  
gear type .....128 bar/89 l./mn

 **Capacities**  
Cooling system .....13 l  
Engine oil.....8,5 l  
Hydraulic oil .....64 l  
Transmission oil.....15,5 l  
Fuel tank.....85 l

 **Weight (with mast and forks)** .....5090kg

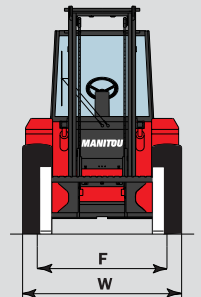
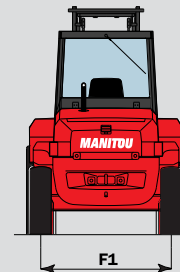
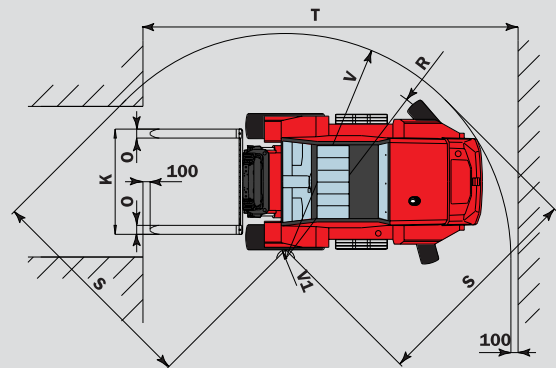
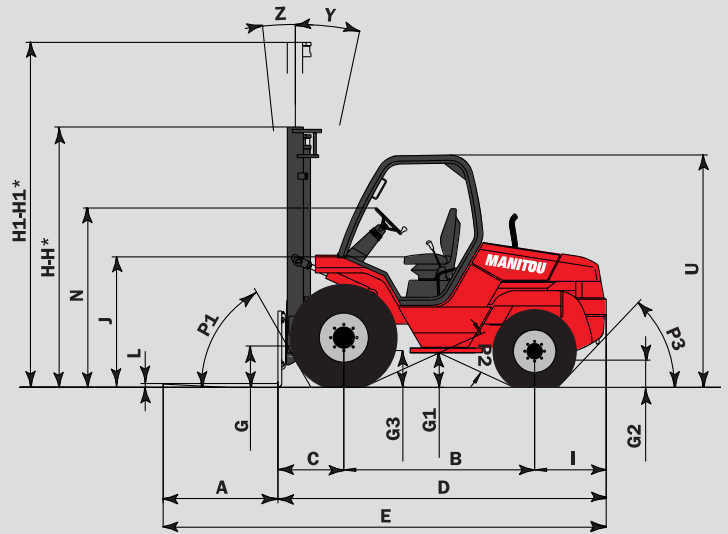

	Roller mast	Slide mast
A	1200	1200
B	1995	1995
C	697	715
D	3442	3460
E	4642	4660
F	1550	1550
F1	1564	1564
G	425	385
G1	385	385
G2	300	300
G3	380	380
H	2715	2855
H1	4745	4655
H*	2205	3055
H1*	4662	4055
I	750	750
J	1400	1400
K	1470	1320
L	40	45
N	1880	1880
O	125	125
P1	60,5°	60,5°
P2	49°	49°
P3	46,5°	46,5°
R	2910	2910
S	3060	3060
T	5030	5285
U	2460	2460
V	3210	3210
V1	300	300
W	1900	1900
Y	12°	10°
Z	6°	6°

mm

### Standard equipment

- Torque converter transmission
- Driver protector with tinted front windscreen and rear window
- Skai seat
- Front and rear wipers
- Left-hand outside rear-view mirror
- Steering wheel with reverse control
- Hydraulic differential lock
- Load damper
- ...

### Options

- Enclosed cab with tinted windows and heating front and rear wipers, front windscreen washer
- Revolving light
- Audible back-up warning signal
- Road lighting
- Work lighting
- Slide masts
- Miscellaneous accessories, such as buckets, sideshift carriage, grabs, etc.

This equipment described in this leaflet may be standard, optional, or unavailable, depending on the versions. For more details, contact your MANITOU dealer.