

750T

Tele Wheel Loader 750T



The telescopic amongst wheel loaders

Compact and manoeuvrable tele wheel loaders for a variety of applications. With an optimised power to weight ratio, low shipping weight and continuous high payload, the efficiency of this model series is of great benefit to end users.

- Fully-fledged wheel loaders with extra range as well as stacking and dumping height
- One-piece frame and all-wheel steering
- Hydraulic quick coupler system and parallel-controlled loading system
- Spacious cabin with perfect all-round visibility
- Efficient drive and low operating costs

750T

Tele Wheel Loader 750T

Technical specifications

Operating data

Bucket capacity (standard bucket)	0,75 m ³
Operating weight	5.100 kg

Engine / Motor

Engine / Motor manufacturer	Deutz
Engine performance	45 kW

Power transmission

Travel speed	20 km/h
Travel speed (optional)	30 km/h
Differential lock	Self-locking differential
Standard tires	12.5-18

Steering and operating hydraulics

Flow rate (pump)	71 l/min
Pressure (maximum)	210 bar

Kinematics

Tipping load (with bucket, retracted)	2.700 kg
Payload (S=1.25, retracted)	1.730 kg

Additional technical data is available in the detailed brochure in the informational material section

Dimensions

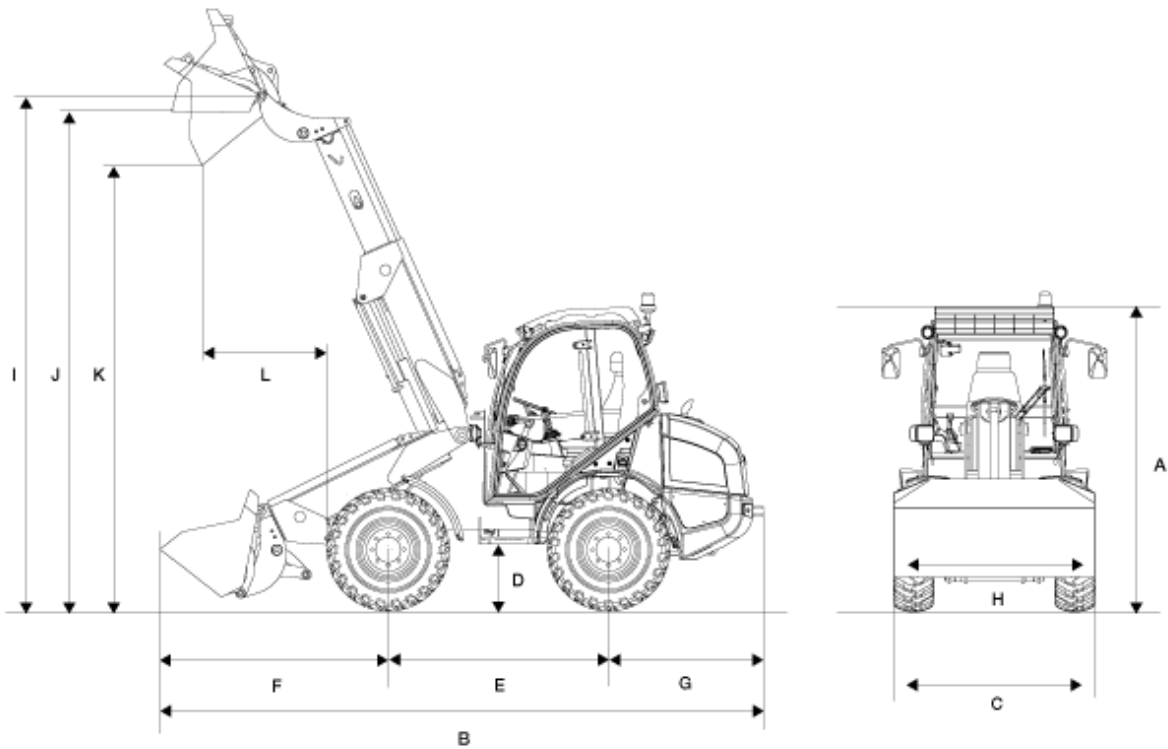

A	Height	2.580 mm
B	Length	5.500 mm
C	Width	1.720 mm
D	Ground clearance	300 mm
E	Wheelbase	1.920 mm
F	Center of front axle to tip of teeth	2.230 mm
G	Center of rear axle to end of vehicle	1.350 mm
H	Bucket width	1.750 mm
I	Bucket pivot point (extended)	4.660 mm
J	Overhead loading height (extended)	4.510 mm
K	Dumping height (extended)	4.000 mm
L	Dump reach (extended)	1.230 mm
	Stack height (extended)	4.440 mm

Turning radius (over tyres)

2.550 mm

Information on suitable accessories can be found on our website.

The right to make changes is reserved in the interests of ongoing further developments. You can find more information on the engine power in the operator's manual. The actual power output figures may vary due to specific operating conditions.

Information on suitable accessories can be found on our website. More detailed information on engine power can be found in the operator's manual; the stated power may vary due to specific operating conditions. Subject to alterations and errors excepted. Applicable also to illustrations. Copyright © 2014 Kramer-Werke GmbH.