

HY-BRID LIFTS™

BY CUSTOM EQUIPMENT INC

OPERATIONS & SAFETY MANUAL
SELF-PROPELLED AERIAL WORK PLATFORM

SUPO-716
REV A



HB-1230CE

SERIES III

Original instructions are written in English.

The purpose of this Operations and Safety manual is to provide users with the instructions and operating procedures essential to properly and safely operate the Custom Equipment Hy-Brid Lift for its intended purpose, and to position personnel and their necessary tools and materials.



**THE OPERATION AND SAFETY MANUAL MUST BE
READ AND UNDERSTOOD PRIOR TO OPERATING THE MACHINE.**

- The user/operator should not accept operating responsibility until the manual has been read and understood as well as having operated the lift under supervision of an experienced and qualified operator.
- Because the manufacturer has no direct control over machine application and operation, proper safety practices are the responsibility of the user and all operating personnel.



**ANY MODIFICATION ON THIS MACHINE WITHOUT THE EXPRESS WRITTEN CONSENT OF THE
MANUFACTURER IS PROHIBITED.**

Fall protection notice:

The guardrail system around the perimeter of the platform is the fall protection system for self-propelled elevating work platforms per the EN 280 Standard. It is prohibited to use an Aerial Work Platform manufactured by Custom Equipment, Inc. With any portion—or all—of the guardrails removed. Lanyard anchorage points on this type of equipment are not required to conform to the applicable standard. However, if anchorage points for lanyard attachments are required by site authorities or other regulations, the anchorage points on all equipment manufactured by Custom Equipment, Inc. Are recommended to be used for work positioning restraints of personnel only. Lanyard lengths are to be determined by operator/owner to restrict the operator to the confines within the guardrail system.

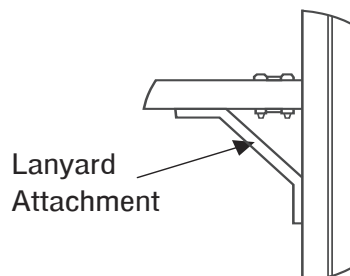

**USE OF FALL ARREST SYSTEMS ATTACHED TO ANCHORAGE POINTS
ON EQUIPMENT MAY CAUSE MACHINE TO TIP, RESULTING IN SERIOUS INJURY OR DEATH.**

TABLE OF CONTENTS

NOTES.....	2
FORWORD	3
TABLE OF CONTENTS	4
INDEX OF FIGURES.....	5
SECTION 1 PRODUCT DESCRIPTION	6
1.1 GENERAL	6
1.2 CE DECLARATION OF CONFORMITY	6
1.3 MACHINE SPECIFICATIONS	7
SECTION 2 SAFETY.....	10
2.1 SAFETY SYMBOLS	10
2.2 GENERAL RULES AND PRECAUTIONS.....	10
2.3 SAFETY FEATURES.....	11
2.4 SAFETY INDICATORS & INTERLOCKS.....	11
2.5 SAFETY CONTROLS.....	12
2.6 MAINTENANCE LOCK.....	13
2.7 SAFETY GUIDELINES.....	13
SECTION 3 DECALS	16
3.1 DECAL LOCATIONS	16
3.2 DECAL DESCRIPTIONS.....	17
3.3 DECAL SYMBOLS.....	18
SECTION 4 TRANSPORT, HANDLING & STORAGE.....	21
4.1 PRELIMINARY UNPACKING INSTRUCTIONS AND DEALER INSPECTION	21
4.2 STORAGE.....	21
4.3 PREPARATION FOR TRANSPORT	21
4.4 LIFTING AND TIE-DOWN POINTS.....	22
4.5 FORK LIFT POCKETS	22
SECTION 5 OPERATION	24
5.1 BEFORE YOU OPERATE	24
5.2 STARTUP/SHUT DOWN.....	25
5.3 ERROR ALARMS	26
5.4 DRIVING AND STEERING	27
5.5 ELEVATING AND LOWERING	27
5.6 EXTENDING THE PLATFORM.....	28
5.7 DAILY MAINTENANCE	29
5.8 CHARGING THE BATTERY	29
5.9 BATTERY DISPLAYS.....	30
SECTION 6 PRE-START INSPECTION	31
6.1 PRE-START INSPECTION CHECKLIST.....	31

INDEX OF FIGURES

FIGURE 1: Pothole Guards10

FIGURE 2: Down Instruction Decal11

FIGURE 3: Emergency Lowering Controls11

FIGURE 4: Maintenance Lock Storage12

FIGURE 5: Maintenance Lock Use12

FIGURE 6: Decal Locations14

FIGURE 7: Caster Lock19

FIGURE 8: Caster Lock in Use19

FIGURE 9: Brake Release Handle Location19

FIGURE 10: Tie-Down Points, Rear20

FIGURE 11: Tie-Down Points, Front20

FIGURE 12: Fork Pockets20

FIGURE 13: Center of Gravity21

FIGURE 14: Base Controls22

FIGURE 15: Platform Controls22

FIGURE 16: Main Power switch23

FIGURE 17: Main Power switch OFF23

FIGURE 18: Main Power switch knob removed23

FIGURE 19: Secure Location23

FIGURE 20: Slide Lock Handle26

FIGURE 21: Battery Charger LED Display28

SECTION 1 | PRODUCT DESCRIPTION

1.1 | GENERAL

Custom Equipment's Hy-Brid Scissors Lift is an aerial work platform designed to be safe and reliable. The purpose of the machine is to elevate personnel, along with their necessary tools and materials to overhead work locations.

Manufacturer approval is required for any use other than the intended use.

Before operation, the operator must read and understand the manufacturer's operating instructions and user's safety rules, or have them explained, understand all labels, warnings, and instructions displayed on the aerial platform or have them explained, ensure that all occupant of the aerial platform wear appropriate protective equipment for the conditions, including the environment in which the aerial platform will be operated.

The operator must inspect the workplace for environmental hazards such as, but not limited to drop-offs, holes, slopes, debris, floor or overhead obstructions, surface, wind and weather conditions, or presence of unauthorized persons. Vibration does not create significant hazards on this machine.

1.2 | CE DECLARATION OF CONFORMITY

We hereby declare that the above mentioned machine has been assessed, tested and approved in accordance with the requirements of the Machinery Directive 2006/42/EEC using the document EC Community Legislation on Machinery and taking guidance from EN280:2001 + A2:2013.

Model Number: HB-1230CE S3
Machine Type: Mobile Elevating Work Platform
Applicable Harmonised Standard: EN280:2001+A2:2013

Manufacturer:
Custom Equipment, Inc.
2647 Hwy 175
Richfield, WI 53076
USA
Phone: 262-644-1300/Fax: 262-644-1320
www.hybridlifts.com

Authorized Representative:
Collé Rental and Sales
Nusterweg 100
6136 KV Sittard
The Netherlands

Notified Body:
TÜV Nederland QA B.V.
de Waal 21 C
5684 PH Best
the Netherlands
Registration Number: CE1231

Certificate Number: 46287/20141229

1.3 | MACHINE SPECIFICATIONS

	HB-1230CE	
Working Height (maximum)	18.6 ft	5.7 m
Platform Height (maximum)	12 ft	3.66 m
Stowed Height	64 in	1.63 m
Ground Clearance (Pothole Guard Stowed)	2.86 in	7.3 cm
Ground Clearance (Pothole Guard Engaged)	0.53in	1.3 cm
Overall Width	30 in	0.76 m
Overall Length	62 in with step	1.57 m with step
Platform (Retracted, Inside)	25.5 in x 53 in	0.64 m x 1.35 m
Slide-Out Deck Length	28.75 in	0.73 m
Guard Rail Height	43.3 in	1.1 m
Platform Entrance	20 in	0.51 m
Step Height	10.2 in	0.26 m
Wheel Base	46 in	1.17 m
Wheel Track	24 in	0.62 m
Turning Radius (Inside)	Zero	
Tire Size (Solid, Non-Marking) - Front / Rear	8 in / 12 in	20.3 cm / 30.5 cm

RATED LOAD

Lift Capacity (Evenly Distributed):	550lb / 1 Persons	249.5 kg / 1 Persons
Slide-Out Deck Capacity	250 lb / 1 Person	113.4 kg / 1 Person
Horizontal/Manual Force	45 lb	200 N

FLOOR LOADING

Machine Weight (Unloaded) (Approx.)	1610 lb	730.3 kg
Minimum Wheel Load-Contact Pressure	103.4 psi	713.1 kPa
Maximum Wheel Load-Contact Pressure	138.8 psi	956.6 kPa
Minimum Machine Loading-Floor Pressure	137.9 psf	6.6 kPa
Maximum Machine Loading-Floor Pressure	185.0 psf	8.9 kPa

ENVIRONMENTAL LIMITATIONS

Wind	No Windy Conditions/Indoor Use Only	
Rated Slope	Level Surface	
Tilt Sensor Activated	2° Longitudinal/1.5° Lateral	
Gradeability (Stowed Position)	25% (14° Unloaded)	
Temperature	-4°F to 104°F	-20°C to 40°C
Vibration	8.2 ft/s ² max	2.5 m/s ² max
Sound - Normal Use, Alarms	86 dB, 100 dB	86 dB, 100 dB

POWER SYSTEMS - Drive System (Proportional Electric):

Drive Speed (Platform Elevated)	0-0.75 mph, proportional	0-0.34 m/s, proportional
Drive Speed (Platform Lowered)	0-2.2 mph, proportional	0-1 m/s, proportional
Lift/Lower Speed	18 s (proportional)/16 s	18 s (proportional)/16 s
Hydraulic Pressure (max)	1000 psi	6895 kPa
Hydraulic Fluid Capacity	1 gal	3.55 L
Power System-Voltage	24V DC	24V DC
Batteries-Deep Cycle Marine	(2) 12V Group 27 AGM	(2) 12V Group 27 AGM

THIS PAGE WAS INTENTIONALLY LEFT BLANK

SECTION 2 | SAFETY

2.1 | SAFETY SYMBOLS



FAILURE TO FOLLOW THIS WARNING WILL CAUSE DEATH OR PERSONAL INJURY.

“DANGER” indicates an imminently hazardous situation, which, if not avoided, will result in death or serious injury.



FAILURE TO FOLLOW THIS WARNING MAY CAUSE DEATH OR PERSONAL INJURY.

“WARNING” indicates a potentially hazardous situation, which, if not avoided, could result in death or serious injury



FAILURE TO FOLLOW THIS WARNING MAY CAUSE INJURY OR DAMAGE TO EQUIPMENT.

“CAUTION” indicates a potentially hazardous situation which, if not avoided, could result in minor or moderate injury or damage to equipment

2.2 | GENERAL RULES AND PRECAUTIONS

Custom Equipment, Inc. designed the Hy-Brid Lift self-propelled scissor lift to be safe and reliable. It is intended for elevating personnel, along with their necessary tools and materials to overhead work locations. Vibration does not create significant hazards on this machine.

An operator of any type of work platform is subject to certain hazards that cannot be protected by mechanical means. It is therefore essential that operators be competent, careful, physically and mentally fit and thoroughly trained in safe operation of this machine. Although Custom Equipment, Inc. conforms to specified EN: 280 requirements, it is the responsibility of the owner to instruct operators with the safety requirements made not only by Custom Equipment, Inc., but by the various safety boards in your area, as well as additional requirements set forth by EN: 280 If you come across a situation that you think might be unsafe, stop the platform and request further information from qualified sources before proceeding.



NEVER REACH BETWEEN SCISSORS LINKS OR PROP UP PLATFORM.



STEERING BRACKETS EXTENDING BEYOND THE SIDES OF THE BASE MAY OCCUR IN TIGHT TURNING SITUATIONS.

HY-BRID LIFTS™

Potential damage to walls, etc., may occur in tight turning situations due to the steering brackets extending beyond the sides of the base.

2.3 | SAFETY FEATURES

- Puncture-proof Wheels.
- Guardrails—1.1 m height with 15 cm kick plates.
- Non-slip Deck.
- Entrance Gate.
- Automatic Parking Brake.
- Free Descent Protection. A pressure compensated flow control valve is installed in the hydraulic circuit to prevent the platform from descending in case of a ruptured hydraulic hose. The platform is hydraulically locked with a check valve and has controlled descent when the valve activates.
- Decals: Danger, Caution, and Warning decals are displayed at various locations on this unit.
- Key Switch Security. A key switch is required to prevent unauthorized use.

2.4 | SAFETY INDICATORS & INTERLOCKS

Tilt Alarm

An audible alarm sounds when the machine is tilted more than 2° longitudinally or 1.5° laterally. Elevating and driving functions are inhibited. Lower the platform and move to a level surface.

Load Sensing

An audible alarm sounds, a light flashes, and movement is inhibited when the load exceeds the rated load. Remove the excess load before continuing operation.

Armguard

When lowering the platform, the platform will stop when the ends of the scissor are 50mm apart for 3 seconds. A fast pulse light and audible signal indicates this condition. Release the joystick enable, Look around all sides of the scissors to check for persons at risk. Then continue lowering the platform.

Pothole Protection

Pothole guards are required to be in place when the lift is in the elevated position. If the guards are blocked or not functioning properly, elevating functions will be inhibited. Lower the machine and do not operate until the problem is repaired or the obstruction is removed.

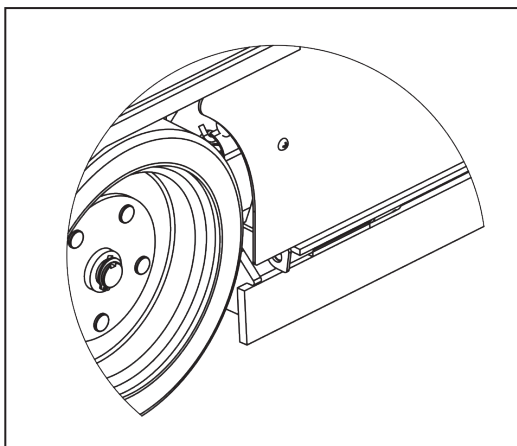

FIGURE 1: Pothole Guards

2.5 | SAFETY CONTROLS

Descent - Manual Override

For manually lowering the scissors, a manual valve on the cylinder is provided. To lower the scissors, pull the cable located near the rear of the machine.

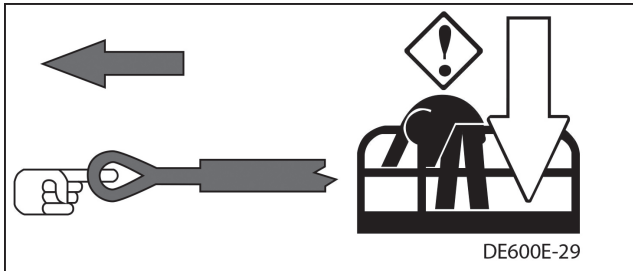

FIGURE 2: Down Instruction Decal

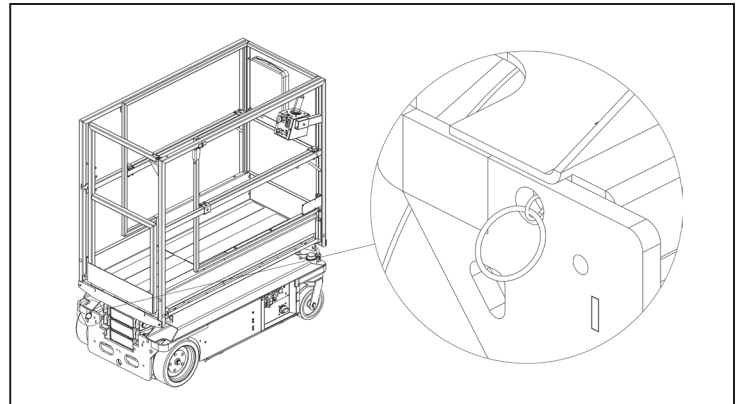

FIGURE 3: Emergency Lowering Controls



IF PLATFORM SHOULD FAIL TO LOWER, DO NOT ATTEMPT TO CLIMB DOWN THE BEAM ASSEMBLY. SERIOUS INJURY MAY RESULT. HAVE AN EXPERIENCED OPERATOR USE THE EMERGENCY LOWERING PROCEDURE TO SAFELY LOWER THE PLATFORM.



BEFORE LOWERING PLATFORM, RETRACT THE DECK EXTENSION.

Emergency Stop

This lift is equipped with two emergency stop switches, one at the platform control and one at the base control, that when activated, will render the unit inoperable until reset. To reset, pull the button out.



PUSHING THE EMERGENCY STOP BUTTON WILL APPLY BRAKES IMMEDIATELY. THIS MAY CAUSE UNEXPECTED PLATFORM MOVEMENT AS THE MACHINE COMES TO A SUDDEN STOP. BRACE YOURSELF AND SECURE OBJECTS ON THE PLATFORM DURING OPERATION OF THE MACHINE.

2.6 | MAINTENANCE LOCK

The maintenance chock must be placed into position whenever the machine is being serviced in the raised or partially raised position. Serious injury and/or death could result if maintenance lock is not used properly.

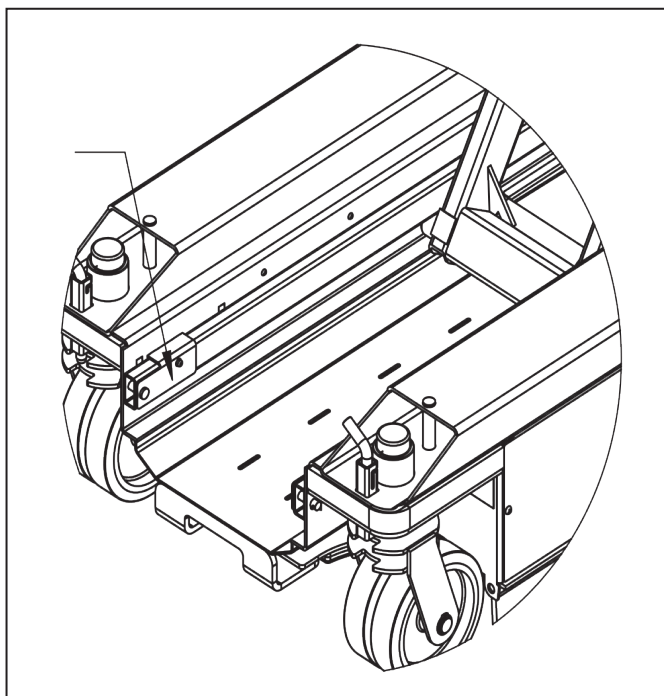

FIGURE 4: Maintenance Lock Storage

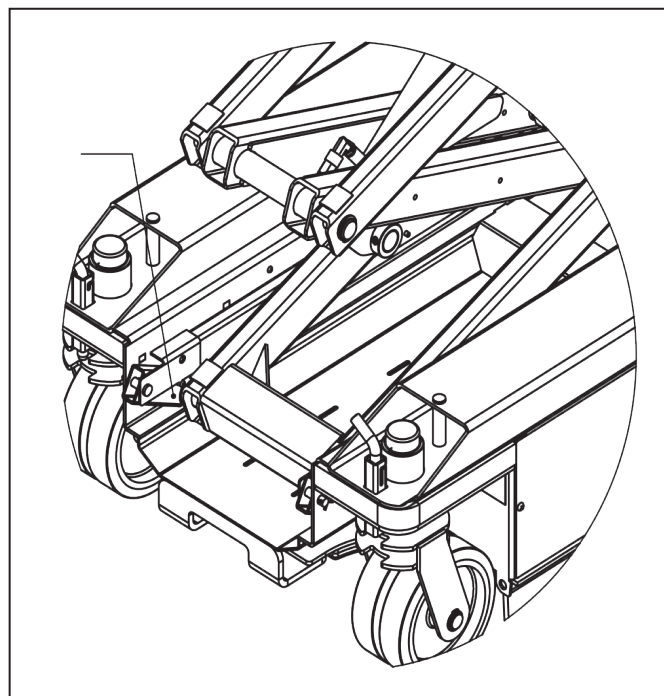

FIGURE 5: Maintenance Lock Use

2.7 | SAFETY GUIDELINES

Only qualified operators may operate this unit.

- All operators must read and understand the Operation and Safety Manual. They must understand all decals and warning labels on unit.
- Do not work on platform if your physical condition is such that you feel dizzy or unsteady in any way.
- Do not neglect/misuse machine. Report any misuse of equipment to proper personnel.
- Prevent unauthorized use; when unit is not in use, remove key.
- It is recommended all personnel on unit wear approved personal protective equipment (PPE), i.e. head gear.

Use machine only for purposes for which it was intended.

- Lift should never be used as a crane.
- Do not exceed the load capabilities of the platform.
- Distribute load evenly over platform floor area.
- Never use unit as electrical grounds for arc welding.
- Do not override any hydraulic, mechanical, or electrical safety devices.

Check job site for unsafe working conditions.

- Watch out for others. Keep others clear of operating platform. Never allow others to pass under a raised platform or position the platform over someone.
- Avoid contact with fixed objects (walls, buildings, or other machinery, etc) or moving vehicles (automobiles, cranes, etc).
- Follow any applicable national traffic regulations.

- Use indoors only. Lift is not designed for windy conditions or electrical storms.
- Unit must be on hard level surface before elevating. Do not operate on incline or uneven surface.
- You must maintain a clearance between any part of the machine, or its load, and any electrical line or apparatus. Follow local power line clearance regulations.



**DO NOT OPERATE MACHINE NEAR POWER LINES.
THE PLATFORM AND ENCLOSURES ARE NOT INSULATED.**

Equipment is only as safe as the operator.

- Do not use ladders or scaffolding on the platform to obtain greater height.
- Do not enter or exit platform while machine is in motion.
- Never mount or dismount a raised platform.
- Make sure entry gate is secured before operating machine from the platform.
- Never belt or tie off to an adjacent structure.
- Secure tools and materials.
- Personnel must maintain a firm footing on the platform floor and work only within the platform area.
- It is recommended to avoid sudden braking or steering. Go slowly and leave more maneuvering room during cold weather operation

Before operation, ensure that the machine is properly serviced.

- Do not use machine if it is not working properly.
- Make sure platform rails and pins are secured.
- Operator shall use the maintenance lock when performing all types of maintenance procedures.
- Do not smoke while charging the battery

THIS PAGE WAS INTENTIONALLY LEFT BLANK

SECTION 3 | DECALS

3.1 | DECAL LOCATIONS

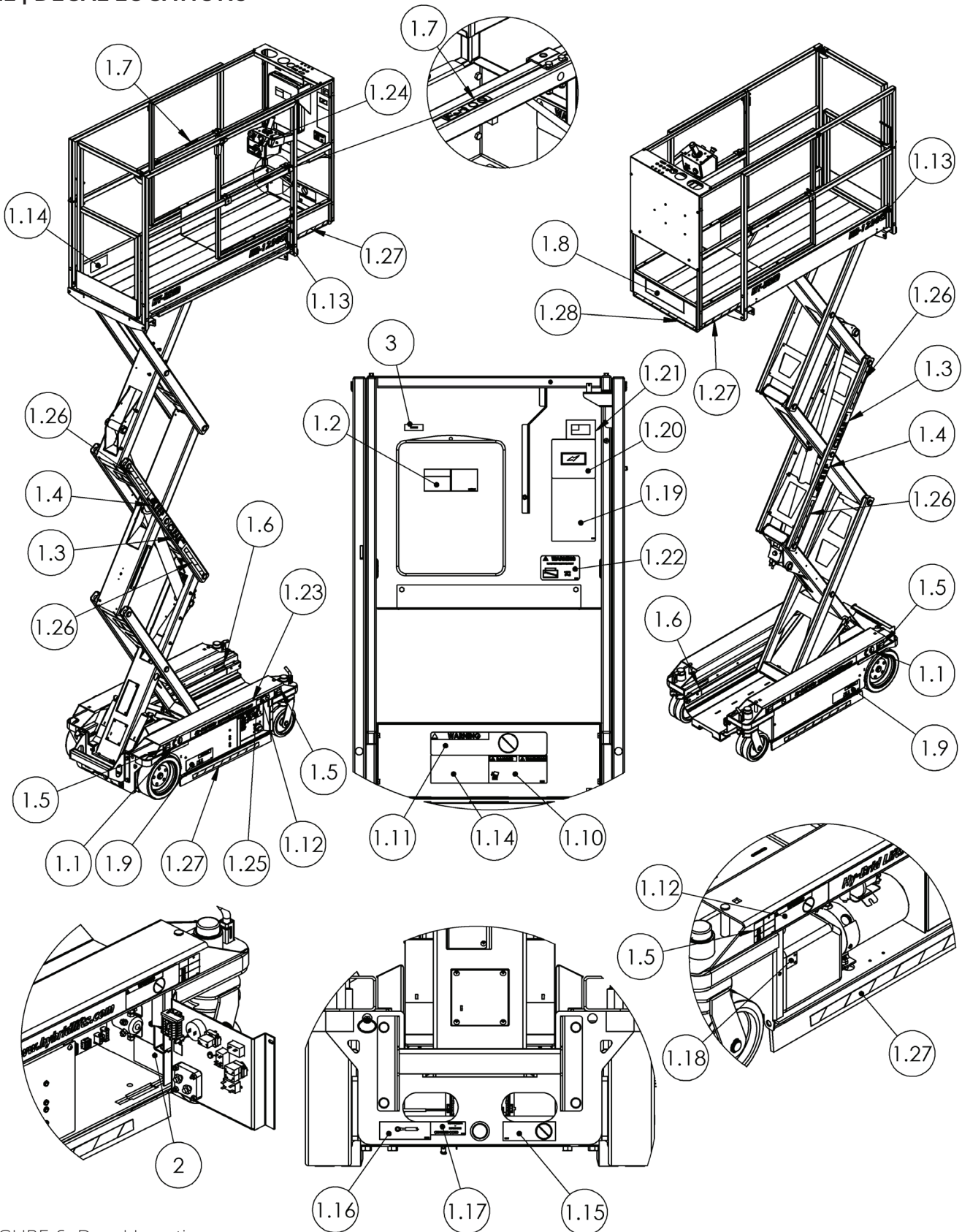

FIGURE 6: Decal Locations

3.2 | DECAL DESCRIPTIONS

ITEM #	PART #	DECAL MEANING OR DESIGNATION	QTY.
1	129-21-315	DECALS,HB-1230 S3 CE	1
1.1	DE718	DECAL,CE	2
1.2	DE600E-10	DECAL,MANUAL BOX	1
1.3	DE708	DECAL,CLEAR	2
1.4	DE707	DECAL,KEEP	2
1.5	DE784	DECAL,WHEEL LOAD HB-1230CE S3	4
1.6	DE600E-14	DECAL,MAINT LOCK	2
1.7	DE746	DECAL,LANYARD ATTACHMENT	2
1.8	DE821	DECAL,LOGO HY-BRID	1
1.9	DE709	DECAL, LWR	2
1.1	DE706	DECAL,UPR HB	1
1.11	DE719	DECAL,CASTERLOCK	1
1.12	DE721	DECAL,CASTERLOCK	2
1.13	DE603-16	MODEL# DECAL-HB-1230CE	2
1.14	DE750	DECAL,CAPACITY,550#,1P,I,W/SO	2
1.15	DE747	DECAL,BRAKE RELEASE/NO TOW	1
1.16	DE751	DECAL,E-DOWN CABLE	1
1.17	DE752	DECAL,CHARGER CORD (EU)	1
1.18	DE679	DECAL,HYDR FLUID	1
1.19	DE756	DECAL,ERROR ALARMS CE	1
1.2	DE777	DECAL,BATT CHARGE DAILY	1
1.21	DE782	DECAL,MADE IN USA	1
1.22	DE649	DECAL,CAPACITY, TOOL TRAY	1
1.23	DE822	DECAL,WEBSITE	2
1.24	DE783	DECAL,CTL UPR ZTR CE	1
1.25	DE705	DECAL,CTL LWR CE ZTR-MID	1
1.26	DE717-62	DECAL,SAFETY STRIPE (12.00)	4
1.27	DE717-61	DECAL,SAFETY STRIPE (24.00)	4
1.28	DE717-63	DECAL,SAFETY STRIPE (22.25)	1
2	N/A	SERIAL NUMBER	1
3	N/A	SERIAL NUMBER REFERENCE	1

3.3 | DECAL SYMBOLS



- No Unauthorized Use
- Do not operate this machine unless you have been trained in safe operation.
- Training includes complete knowledge of the safety and operating instructions contained in the manufacturer’s manual, your employer’s work rules, and applicable government regulations.
- An untrained operator subjects himself and others to death or serious injury.

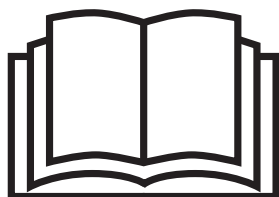

- Read and understand all dangers and warnings in the operator’s manual before operating this machine.
- Improper use of this machine could cause death or serious injury.
- Inspect machine and make sure that it is operating properly, that all name plate and hazard signs are in place and legible, and that the machine is in accordance with the manufacturer’s maintenance requirements contained in the operating and maintenance requirements contained in the operation and maintenance manual and the daily safety checklist.



- Crushing Hazard
- Do not enter the space beneath the work platform or scissor structure unless the maintenance lock is in place.



- Refer to Maintenance Manual
- Only qualified service personnel may service the machine. Failure to comply with listed safety precautions may result in machine damage, personnel injury, or death.
- Replace designated items with manufacturer’s specified equipment only. Failure to use these items may cause instability of platform.



- Batteries produce explosive gas. Only charge batteries in a well-ventilated area.
- Do not expose to sparks or flames.
- Do not smoke while charging battery.

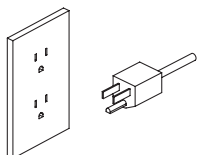

- Battery Charger Cord



- Tip Hazard

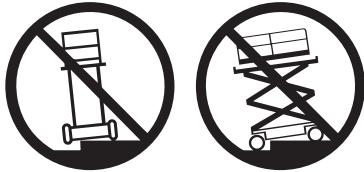

- Tip Hazard
- Do not elevate platform on an incline or step.



- Tip Hazard
- Do not elevate platform on a slope.



- Tip Hazard
- Do not elevate platform on uneven or soft surfaces.

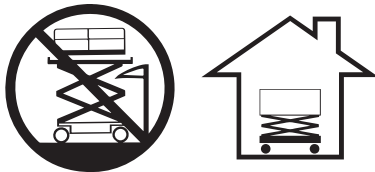

- Indoor Use Only: No Wind Load

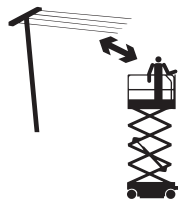
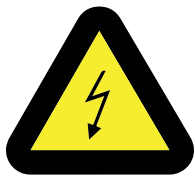

- Electrocutation Hazard
- This machine is not insulated.
- Maintain safe clearance from electrical lines and apparatus. You must allow for machine sway, rock or sag and electrical lines swaying.
- This machine does not provide protection from contact with or proximity to an electrically charged conductor.
- You must maintain a clearance between any part of this machine or its load and any electrical apparatus. Follow local power line regulations.
- Death or serious injury will result from contact or inadequate clearance.



- Brake Release



- Emergency Lowering

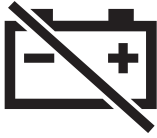

- Battery disconnect



- Fork pocket

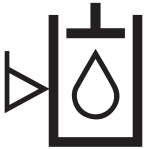

- Hydraulic oil level

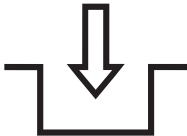

- Engaging mechanical Action: Enable Switch

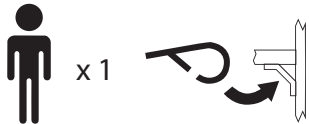

- Lanyard anchorage point location: Capacity 1 Person



- Lanyard anchorage points are for work positioning restraints only, not for fall protection.
- Use of fall arrest systems attached to anchorage points on mobile equipment may cause machine to tip, resulting in serious injury or death.

SECTION 4 | TRANSPORT, HANDLING & STORAGE

4.1 | PRELIMINARY UNPACKING INSTRUCTIONS AND DEALER INSPECTION

Maintenance locks must be engaged prior to inspecting or servicing the unit when the platform is elevated. Inspect machine for any possible damage during shipment; perform pre-delivery inspection. See checklist in the Maintenance Manual. Reset emergency stop switches, if necessary.

4.2 | STORAGE

After periods of storage or exposure to extremes of ambient conditions (heat, cold, moisture, dust etc.) inspect the machine. Refer to the Pre-Delivery/Frequent Inspection Checklist of the Maintenance Manual.

4.3 | PREPARATION FOR TRANSPORT

Lower the work platform to the down position. Bring the platform slide-out extension into the retracted position and lock in place. Turn the key switch to off position. Check the entire machine for loose or unsecured items. Remove any loose items from machine.

To limit caster swivel when loading or unloading, the caster lock pins should be used to lock the casters in the straight position.

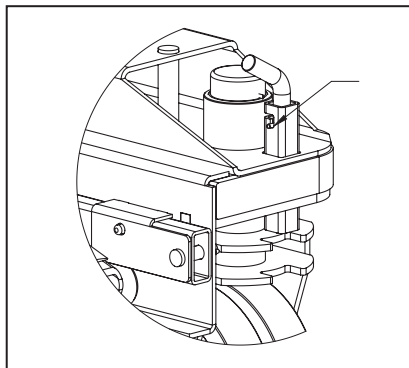

FIGURE 7: Caster Lock

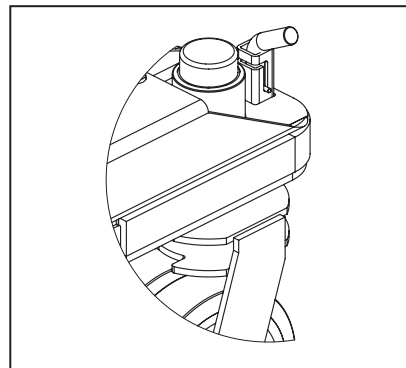

FIGURE 8: Caster Lock in Use

The machine can be pushed by releasing the parking brakes (one for each drive motor) at the rear of the machine. Pull both levers away from the floor. To resume normal operation, make sure both levers are down. Do not attempt to push or tow unit with the brakes applied. Do not push at speeds more than 0.9 m/s (2 mph). Severe gear damage will occur. Towing is not recommended.

NOTE: The drive system will not function if the parking brake is in the down release position.

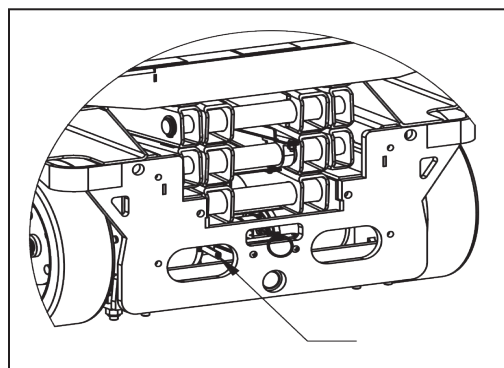

FIGURE 9: Brake Release Handle Location

4.4 | LIFTING AND TIE-DOWN POINTS

Tie-down points are provided for securing the machine on a trailer or truck bed for transport between places of use. They may also be used as lift points.

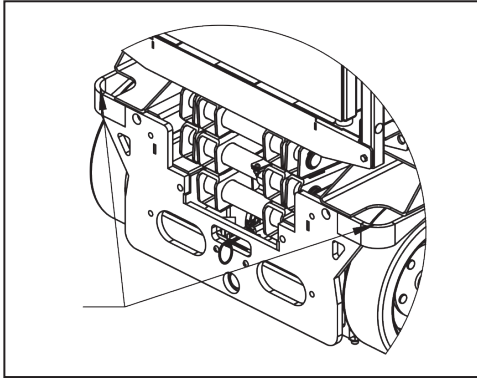

FIGURE 10: Tie-Down Points, Rear

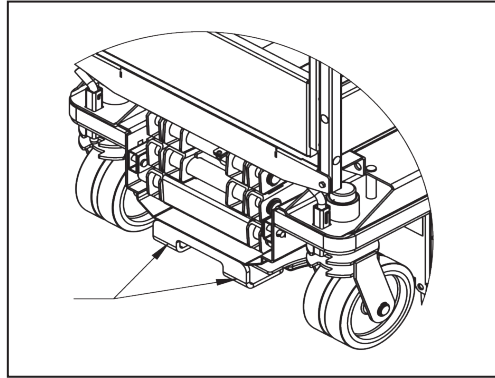

FIGURE 11: Tie-Down Points, Front



DO NOT OVERLOAD BINDERS WHEN SECURING LOAD FOR TRANSPORT

4.5 | FORK LIFT POCKETS

Fork lift pockets are provided from the front and back of the unit for loading and unloading. A forklift from the side of the machine is not recommended. Do not use a forklift underneath the machine from the back. When moving machine with a forklift, do not let machine slide along floor. Bring forklift to a stop and then gently lower the machine.

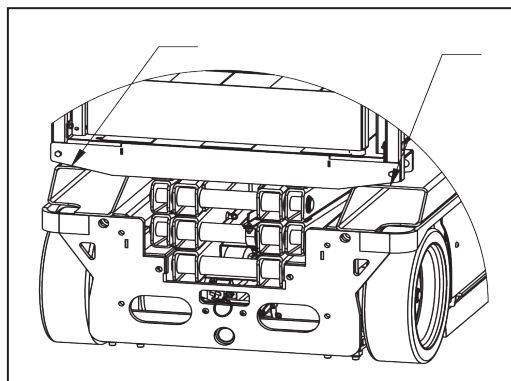

FIGURE 12: Fork Pockets

Center of Gravity

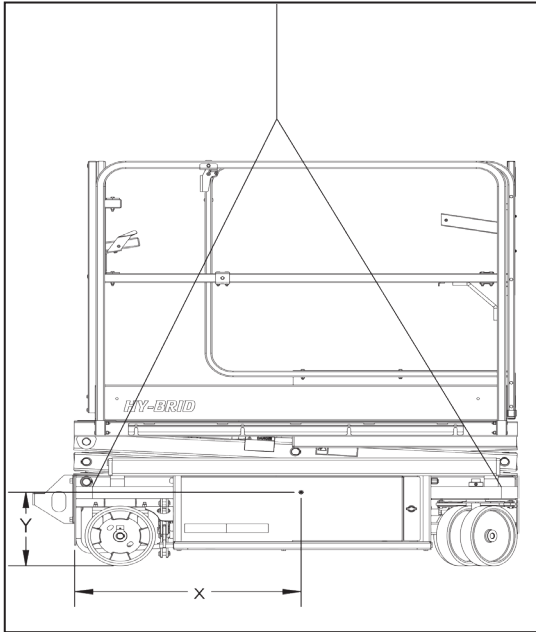

FIGURE 13: Center of Gravity

	X Axis	Y Axis
HB-1230CE	28 in (71 cm)	13 in (33 cm)

SECTION 5 | OPERATION

5.1 | BEFORE YOU OPERATE

Before use each day or at the beginning of each shift, the machine shall be given a visual inspection and functional test. Repairs (if any) must be made prior to operating the machine, as it is critical to ensure safe operation of the machine. A checklist for pre-start inspection can be found in this manual.

Base Controls

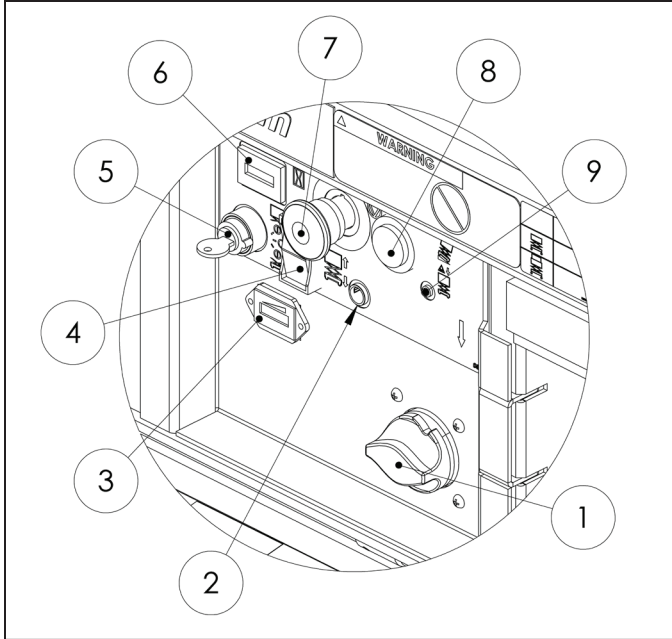

FIGURE 14: Base Controls

Item	Control/Indicator
1	Master Power Switch Operation described as follows
2	Diagnostic Light
3	Battery Volt Meter
4	Up/Down Rocker Switch Operation described as follows
5	Key Switch Operation described as follows
6	Hour Meter Displays operation hours
7	Emergency Stop Operation described in Safety Controls Section
8	Beeper See Safety Indicators Section for more information
9	Overload Light

Platform Controls

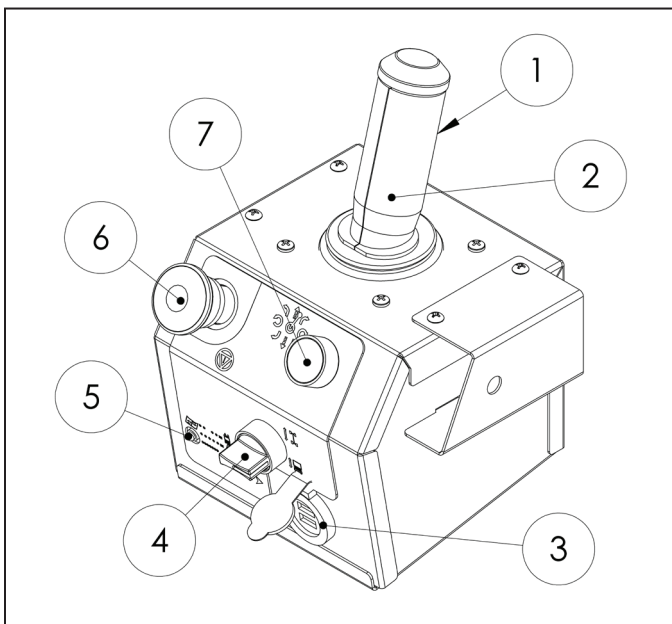

FIGURE 15: Platform Controls

Item	Control/Indicator
1	Drive Enable Trigger Operation described as follows
2	Joystick Operation described as follows
3	USB Power Port
4	Lift/Drive Mode Selection Switch Operation described as follows
5	Overload Light
6	Emergency Stop Operation described in Safety Controls Section
7	Horn Button

5.2 | STARTUP/SHUT DOWN



**THE OPERATOR MUST BE AWARE OF THE ENVIRONMENT.
DO NOT RAISE THE PLATFORM IF THE MACHINE IS NOT ON A FIRM, LEVEL SURFACE.**

Operation Startup & Shutdown Practices

- Check that the work area is safe.
- Check that the Master Power Switch is in the "ON" position
- Ensure that the key in the lower control panel is in the "ON" position for the upper or lower controls. The key should be removed when to upper control location is selected to prevent unauthorized operation from the ground.
- Machine must be on a hard, level, surface before operation.
- Enter the work platform in the stowed position using the constant three point contact method.
- Follow all general rules and precautions stated in this manual
- When finished with the machine, place the platform in the stowed position.
- Park the machine on a level surface.
- Carefully exit the platform using the constant three point contact method.
- NEVER JUMP OFF PLATFORM.
- Remove key from lower control panel to prevent unauthorized use.
- The master power switch knob may be removed when in the isolated position and placed in a secure, padlockable location. (Ex. In the manual box)

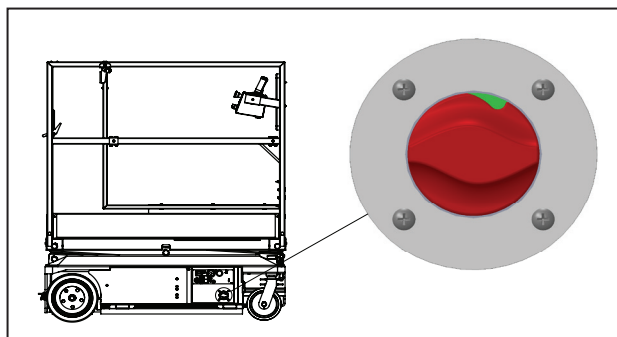

FIGURE 16: Main Power switch

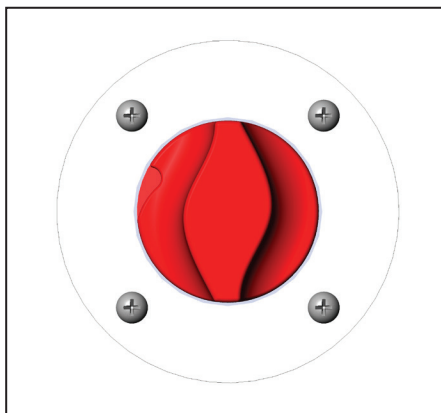

FIGURE 17: Main Power switch OFF

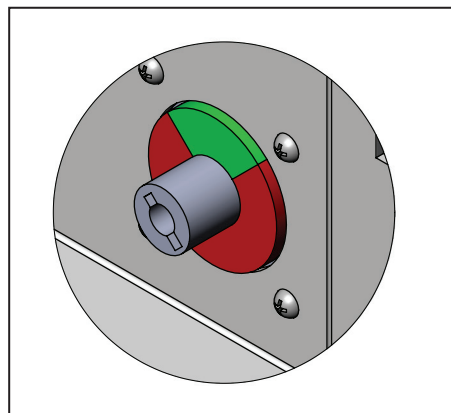

FIGURE 18: Main Power switch knob removed

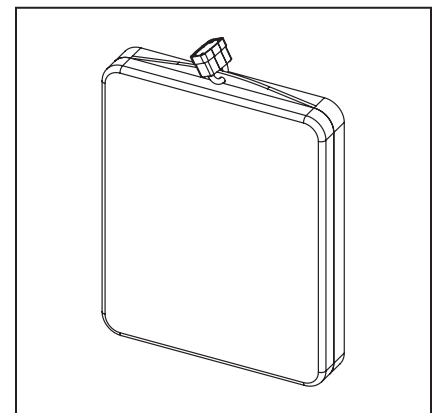

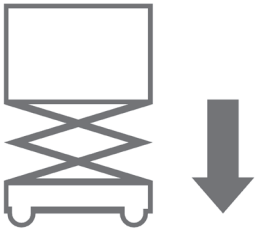



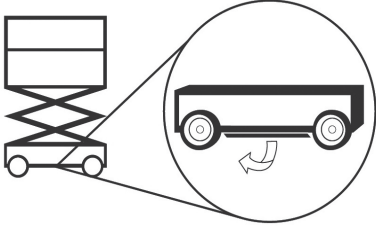
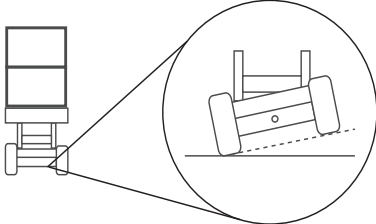

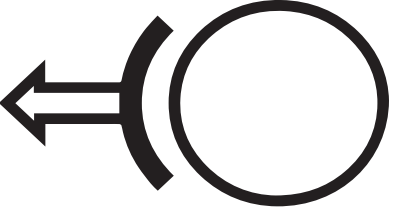

FIGURE 19: Secure Location

5.3 | ERROR ALARMS

The table below lists audible alarms that signal a potential hazard or that an interlock is functioning.

<p>ALARM</p> 	<p>ALERT ILLUSTRATION</p>	<p>MEANING</p>
<p>Slow Pulse</p> 		<p>Machine is descending. Be aware of bystanders and possible obstructions.</p>
<p>Fast Pulse</p> 		<p>The ends of the scissor are 50mm apart. Release the joystick enable, look around all sides of the scissors to check for persons at risk. Then continue lowering the platform.</p>
<p>Medium Pulse</p> 		<p>Machine Begins Elevating and Stops: Pothole Guards Not Engaged-Check for Obstruction</p>
		<p>Drive Axle Not Locked-Move to Level Surface</p>
<p>Solid</p> 		<p>Machine will not drive: Brakes are manually released. Turn handle to engage brakes before using. OR Battery charger is plugged in. Unplug before use.</p>

5.4 | DRIVING AND STEERING



CHECK THAT THE ROUTE OF TRAVEL TO BE TAKEN IS CLEAR OF PEOPLE, OBSTRUCTIONS, DEBRIS, HOLES, AND DROP-OFFS; AND IS CAPABLE OF SUPPORTING THE MACHINE.

Always check front steer wheel direction before driving. If there is resistance in turning the casters while pivoting the machine, steer forward to allow the casters to straighten out before turning.

For best control, distribute the load on the work platform toward the rear of the machine if possible.

To activate drive function, select drive mode using the switch on the platform control box.

To drive, hold the joystick trigger while moving the joystick. Moving the joystick will cause the machine to drive in that direction. Moving the joystick handle away from the operator will cause FORWARD travel, and pulling the joystick toward the operator will cause REVERSE travel. Moving the joystick directly to one side or the other will cause the machine to pivot. Travel speed is proportional and is controlled by the joystick. The farther it is moved, the faster the speed will be. The joystick returns to the neutral position when released.

Braking: For parking, the brake is automatically applied when the joystick is positioned in the center (neutral) position. In the event of a machine failure, the machine can be pushed by releasing the parking brake at the rear of the machine. See the "Preparation for Transport" section of this manual for brake release information.

5.5 | ELEVATING AND LOWERING

Using Upper Platform Controls

Use the key switch to on the lower controls to select the platform controls. To activate elevate/lower function, select elevate mode using the switch on the platform control box.

To drive, hold the joystick trigger while moving the joystick. Moving the joystick handle away from the operator will cause elevating, and pulling the joystick toward the operator will cause lowering. Speed is proportional and is controlled by the joystick. The farther it is moved, the faster the speed will be. The joystick returns to the neutral position when released.

Using Lower Base Controls

Use the key switch to select the lower controls. Pressing the top of the switch raises the platform, pressing the bottom lowers the platform.

5.6 | EXTENDING THE PLATFORM

1. Stand on the platform deck.
2. Grip the Slide Lock Handle to allow the deck to slide.
3. Slide the deck out to one of two locking points, one at approximately 15 in (38 cm) extension, the other at approximately 30 in (76.2 cm) extension.
4. Release handle to keep deck in place. Be sure lock is engaged before entering.

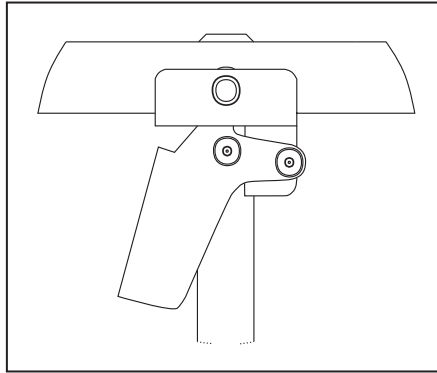

FIGURE 20: Slide Lock Handle



CHECK THAT THE ROUTE OF TRAVEL TO BE TAKEN IS CLEAR OF PEOPLE, OBSTRUCTIONS, DEBRIS, HOLES, DROP-OFFS; AND IS CAPABLE OF SUPPORTING THE MACHINE.



IF THE SLIDE-OUT DECK IS EXTENDED, CHECK FOR CLEARANCE UNDER AREA BEFORE LOWERING PLATFORM.



DO NOT DRIVE UNIT WHEN STANDING ON EXTENSION. STAND ON PLATFORM BEHIND JOYSTICK.

5.7 | DAILY MAINTENANCE

Regular inspection and conscientious maintenance is important to efficient economical operation of this machine. It will help to assure that equipment will perform satisfactorily with a minimum of service and repair. Make checks at the stated intervals or more frequently if required by local operating conditions. The following inspection checklists are included in this manual:

- Pre-Start (required before operation at each work shift)
- Pre-Delivery/Frequent/Annual (Required every 3 months, after periods of storage, and after any alterations or repairs)

The rated life of the machine is Light Intermittent Duty (typical use 10 years, 40 weeks per year, 20 hours per week, 5 load cycles per hour)

Additional maintenance for use by trained personnel is included in a separate Maintenance Manual. Refer to the Maintenance Manual for Pre-Delivery/Frequent and Monthly Checklists and replacement part information.



**FAILURE TO PERFORM INSPECTIONS AND PREVENTATIVE MAINTENANCE
AT RECOMMENDED INTERVALS MAY RESULT IN THE UNIT BEING OPERATED WITH DEFECTS
THAT MAY RESULT IN INJURY OR DEATH OF THE OPERATOR.**

5.8 | CHARGING THE BATTERY

This unit is equipped with 12-volt AGM maintenance-free batteries.

NOTE: The surrounding temperature greatly affects the power reserve within a battery.

EXAMPLE: A battery that is 100% charged at 80° F (27°C) drops to 65% at 32°F (0°C). At 0°F (-18°C), this battery will drop to 40% efficiency.



**BATTERIES GENERATE EXPLOSIVE GASES. KEEP SPARKS AND FLAME
AWAY FROM BATTERIES. DO NOT SMOKE WHILE CHARGING.**

The charger is equipped with an interlock circuit. The unit will not operate while charging. Shortened battery life will result.

To Charge:

- Park the machine on a level surface.
- Plug charger into AC outlet until charged.
- For best battery life, leave the charger plugged in until machine will be used again. The charger will maintain the battery charge.

5.9 | BATTERY DISPLAYS

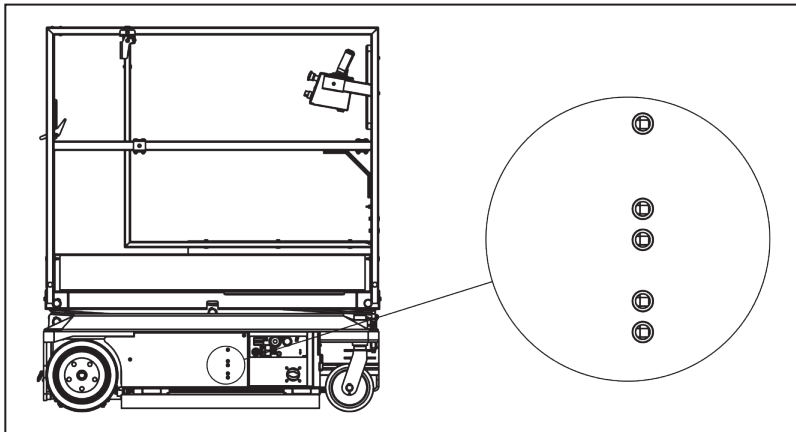

DO NOT OPERATE UNIT WHILE CHARGING. DO NOT DISABLE THE CHARGER INTERLOCK

FIGURE 21: Battery Charger LED Display

How to read the battery displays

Power	Battery 1 Status		Battery 1 Status		This display indicates that the power is on but there is no connection to a battery. The charger must see approximately five (5) volts on a battery to deliver D/C current.
Charging	Ready	Charging	Ready		
Green LED (ON)	Red LED (OFF)	Green LED (OFF)	Red LED (OFF)	Green LED (OFF)	
Power	Battery 1 Status		Battery 1 Status		This display indicates that power is on and that both outputs are delivering D/C current to the batteries.
Charging	Ready	Charging	Ready		
Green LED (ON)	Red LED (ON)	Green LED (OFF)	Red LED (ON)	Green LED (OFF)	
Power	Battery 1 Status		Battery 1 Status		This display indicates that power is on and that both outputs are finished charging and are in a float maintenance mode.
Charging	Ready	Charging	Ready		
Green LED (ON)	Red LED (OFF)	Green LED (ON)	Red LED (OFF)	Green LED (ON)	
Power	Battery 1 Status		Battery 1 Status		A flashing red light indicates there is a problem with a battery, such as low voltage or a bad cell.
Charging	Ready	Charging	Ready		
Green LED (ON)	Red LED (FLASHING)	Green LED (ON)	Red LED (FLASHING)	Green LED (ON)	



NEVER ADD ACID TO BATTERY!

SECTION 6 | PRE-START INSPECTION

6.1 | PRE-START INSPECTION CHECKLIST

Pre-start Inspection (Self-Propelled Models)



THIS CHECKLIST MUST BE USED AT THE BEGINNING OF EACH SHIFT OR AFTER EVERY SIX TO EIGHT HOURS OF USE. FAILURE TO DO SO COULD AFFECT THE SAFETY OF THE OPERATOR.

Model: _____ Serial Number: _____

- Keep inspection records up-to-date.
- Record and report all discrepancies to your supervisor.
- A dirty machine cannot be properly inspected.

Y-Yes/Acceptable	N-No/Unacceptable	R-Repaired	N/A - Not equipped with this feature	Y	N	R	N/A
VISUAL INSPECTIONS							
There are no loose or missing parts.				<input type="checkbox"/>	<input type="checkbox"/>	<input type="checkbox"/>	<input type="checkbox"/>
Check that warning and instructional labels are legible and secure. Ensure that load capacity is clearly marked.				<input type="checkbox"/>	<input type="checkbox"/>	<input type="checkbox"/>	<input type="checkbox"/>
Check the platform rails and safety gate for damage.				<input type="checkbox"/>	<input type="checkbox"/>	<input type="checkbox"/>	<input type="checkbox"/>
Platform and base controls are not missing, damaged, or disconnected.				<input type="checkbox"/>	<input type="checkbox"/>	<input type="checkbox"/>	<input type="checkbox"/>
Electrical cables and wires are not torn, frayed, or disconnected.				<input type="checkbox"/>	<input type="checkbox"/>	<input type="checkbox"/>	<input type="checkbox"/>
Hydraulic hoses are not torn or loose, and there are no leaks. Hoses and the cables have no worn areas or chafing.				<input type="checkbox"/>	<input type="checkbox"/>	<input type="checkbox"/>	<input type="checkbox"/>
Check the tires for damage. Check that wheel axle retaining rings and any set screw(s) in rear wheel are tight.				<input type="checkbox"/>	<input type="checkbox"/>	<input type="checkbox"/>	<input type="checkbox"/>
Check that all snap rings are secure in grooves on pivot pins.				<input type="checkbox"/>	<input type="checkbox"/>	<input type="checkbox"/>	<input type="checkbox"/>
FUNCTIONAL TESTS							
Gate closes automatically and latches.				<input type="checkbox"/>	<input type="checkbox"/>	<input type="checkbox"/>	<input type="checkbox"/>
Platform Controls: Check all switches and push buttons for proper operation.							
Emergency Stop (Stops all movement)				<input type="checkbox"/>	<input type="checkbox"/>	<input type="checkbox"/>	<input type="checkbox"/>
For Actuator-Steered models: Enable Switch (Does not elevate unless enable is pressed)				<input type="checkbox"/>	<input type="checkbox"/>	<input type="checkbox"/>	<input type="checkbox"/>
For Counter-Rotate Steering models: Drive & Up/Down Mode Switch (Selects drive/steer or elevate mode)				<input type="checkbox"/>	<input type="checkbox"/>	<input type="checkbox"/>	<input type="checkbox"/>
Joystick (Return to neutral, drives forward & reverse)				<input type="checkbox"/>	<input type="checkbox"/>	<input type="checkbox"/>	<input type="checkbox"/>
Enable Trigger (Must be activated for joystick-operated movement)				<input type="checkbox"/>	<input type="checkbox"/>	<input type="checkbox"/>	<input type="checkbox"/>
For Actuator-Steered models: Thumb rocker steers right & left				<input type="checkbox"/>	<input type="checkbox"/>	<input type="checkbox"/>	<input type="checkbox"/>
For Counter-Rotate Steering models: Elevates & lowers				<input type="checkbox"/>	<input type="checkbox"/>	<input type="checkbox"/>	<input type="checkbox"/>
If so equipped, horn sounds when button is pressed.				<input type="checkbox"/>	<input type="checkbox"/>	<input type="checkbox"/>	<input type="checkbox"/>
Base Controls: Check all switches and push buttons for proper operation.							
Emergency Stop (Stops all movement)				<input type="checkbox"/>	<input type="checkbox"/>	<input type="checkbox"/>	<input type="checkbox"/>
For Actuator-Steered models: Key Switch (On or Off)				<input type="checkbox"/>	<input type="checkbox"/>	<input type="checkbox"/>	<input type="checkbox"/>
For Counter-Rotate Steering models: Key Switch (Selects Platform Control, Ground Control, or Off)				<input type="checkbox"/>	<input type="checkbox"/>	<input type="checkbox"/>	<input type="checkbox"/>
Up/Down Rocker Switch (Elevates, Lowers)				<input type="checkbox"/>	<input type="checkbox"/>	<input type="checkbox"/>	<input type="checkbox"/>
Descent Alarm (Not damaged, sounds for descent; may also sound for drive & elevate, if so equipped)				<input type="checkbox"/>	<input type="checkbox"/>	<input type="checkbox"/>	<input type="checkbox"/>
Tilt Alarm (Not damaged, sounds when tilted and machine elevated above designated height)				<input type="checkbox"/>	<input type="checkbox"/>	<input type="checkbox"/>	<input type="checkbox"/>
If so equipped, elevating beyond this height may also be prevented.				<input type="checkbox"/>	<input type="checkbox"/>	<input type="checkbox"/>	<input type="checkbox"/>
Master Power Switch disconnects battery				<input type="checkbox"/>	<input type="checkbox"/>	<input type="checkbox"/>	<input type="checkbox"/>
Wheels: Front and rear wheels rotate freely.				<input type="checkbox"/>	<input type="checkbox"/>	<input type="checkbox"/>	<input type="checkbox"/>
For Counter-Rotate Steering models: Front wheels pivot freely.				<input type="checkbox"/>	<input type="checkbox"/>	<input type="checkbox"/>	<input type="checkbox"/>
Drives in slow speed when elevated.				<input type="checkbox"/>	<input type="checkbox"/>	<input type="checkbox"/>	<input type="checkbox"/>
Brakes: Machine stops when joystick released.				<input type="checkbox"/>	<input type="checkbox"/>	<input type="checkbox"/>	<input type="checkbox"/>
Pothole guards deploy and lock when platform is elevated.				<input type="checkbox"/>	<input type="checkbox"/>	<input type="checkbox"/>	<input type="checkbox"/>
Lift does not elevate when pothole guards are blocked.				<input type="checkbox"/>	<input type="checkbox"/>	<input type="checkbox"/>	<input type="checkbox"/>

Date: _____ Inspected by: _____

HY-BRID LIFTS™

BY CUSTOM EQUIPMENT INC

Self-Propelled Aerial Work Platform
Operation & Safety Manual
HB-1230CE

© 2016 Custom Equipment, Inc.
2647 Highway 175
Richfield, WI 53076
U.S.A.
Tel. +1-262-644-1300
Fax: +1-262-644-1320
www.hybridlifts.com
Service@Customequipmentlifts.com

"Hy-Brid Lifts" is a trademark of Custom Equipment, Inc.
These machines comply with specified EN 280 requirements

Revision Date: June 2016

Printed In The USA