

# **HY-BRID LIFTS™**

BY CUSTOM EQUIPMENT INC

## **PARTS MANUAL**

PUSH-AROUND AERIAL WORK PLATFORM

SUPO-731

REV A



---

# **HB-P527**

# **HB-P3.6**

---

SERIES I

Models Covered:

HB-P527 Serial # Ranges:

D04-10001-19999

HB-P3.6 Serial # Ranges:

E04-10001-19999



# FOREWORD

Original instructions written in English.

This parts manual is applicable to the following machines:

Model HB-P527 Serial # Ranges:

D04-10001-19999

Model HB-P3.6 Serial # Ranges:

E04-10001-19999

The serial number is located in the rear left wheel well. An additional reference is usually located on the inside of the front toe board.

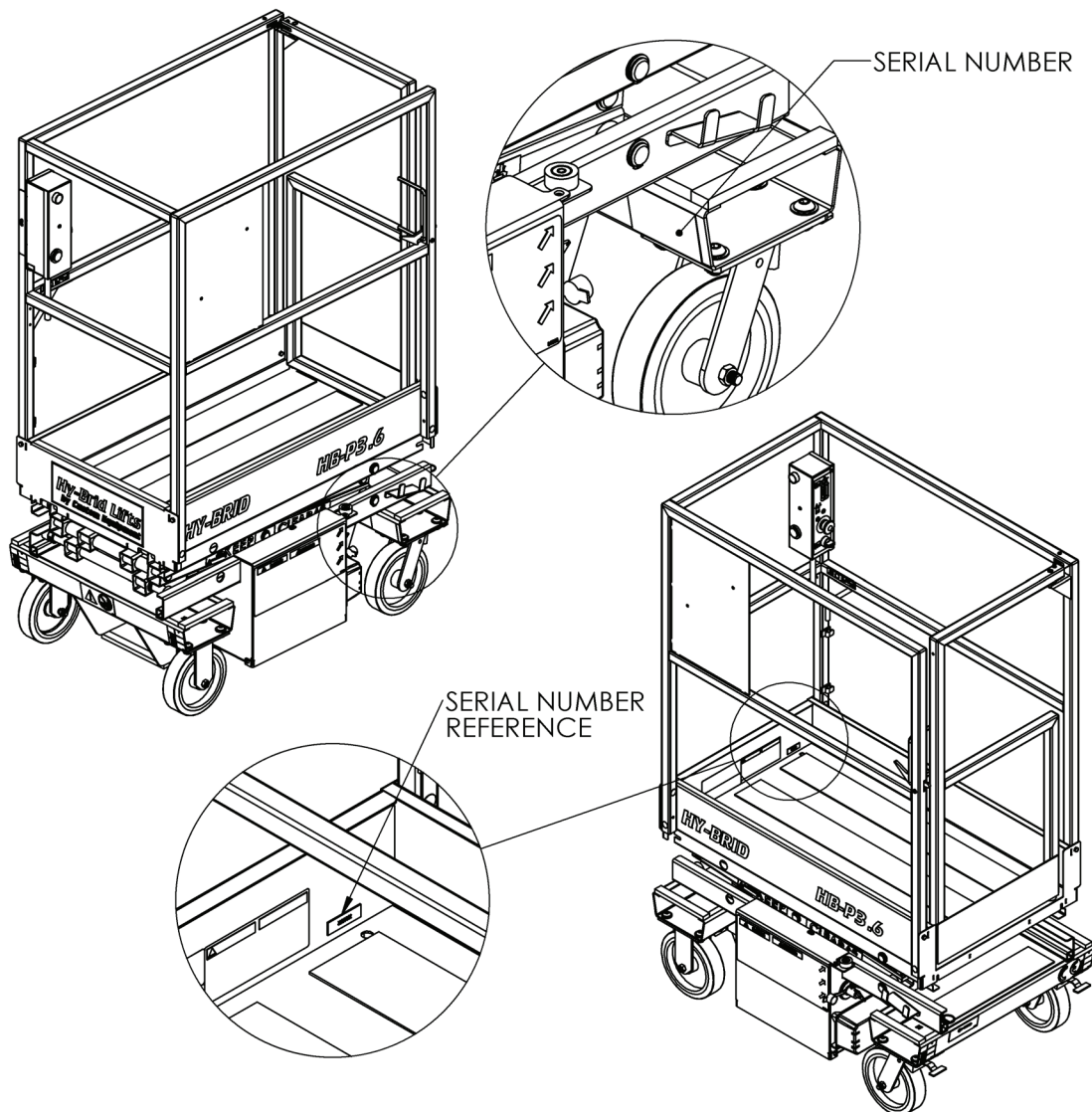

# TABLE OF CONTENTS

---

NOTES.....	2
FOREWORD.....	3
TABLE OF CONTENTS.....	4
INDEX OF FIGURES.....	5
<b>SECTION 1   BASE</b> .....	<b>6</b>
1.1   CASTER PARTS.....	6
1.2   CASTER SUBPARTS.....	7
1.3   BRAKE SUBPARTS.....	7
1.4   PUMP SUBPARTS.....	8
1.5   MISCELLANEOUS BASE PARTS.....	9
<b>SECTION 2   CONTROLS</b> .....	<b>10</b>
2.1   ELECTRICAL PARTS.....	10
2.2   UPPER CONTROL PARTS.....	12
2.3   ENABLE SWITCH SUBPARTS.....	13
2.4   E-STOP SWITCH SUBPARTS.....	13
2.5   MASTER POWER SWITCH SUBPARTS.....	14
2.6   UP/DOWN SWITCH SUBPARTS.....	14
<b>SECTION 3   SCISSORS</b> .....	<b>16</b>
3.1   SCISSORS PARTS.....	16
3.2   PUMP & CYLINDER SUBPARTS.....	18
<b>SECTION 4   PLATFORM &amp; RAILS</b> .....	<b>20</b>
<b>SECTION 5   DECALS</b> .....	<b>22</b>
5.1   DECALS-ANSI/CSA.....	22
5.2   DECALS-CE.....	24
<b>SECTION 6   OPTIONS &amp; MISCELLANEOUS</b> .....	<b>26</b>

# INDEX OF FIGURES

---

FIGURE 1: Caster Parts ..... 6  
FIGURE 2: Caster Subparts ..... 7  
FIGURE 3: Brake Subparts ..... 7  
FIGURE 4: Pump Parts ..... 8  
FIGURE 5: Pump Subparts ..... 10  
FIGURE 6: Miscellaneous Parts..... 12  
FIGURE 7: Electrical Parts..... 14  
FIGURE 8: Upper Control Parts ..... 16  
FIGURE 9: Enable Switch Subparts..... 17  
FIGURE 10: E-Switch Subparts..... 17  
FIGURE 11: Master Power Switch Subparts ..... 18  
FIGURE 12: Up/Down Switch Subparts ..... 18  
FIGURE 13: Scissors Parts..... 20  
FIGURE 14: Cylinder Subparts..... 22  
FIGURE 15: Platform & Rails ..... 24  
FIGURE 16: Decals-ANSI/CSA ..... 26  
FIGURE 17: Decals-CE..... 28  
FIGURE 18: Options & Miscellaneous..... 30

# SECTION 1 | BASE

## 1.1 | CASTER PARTS

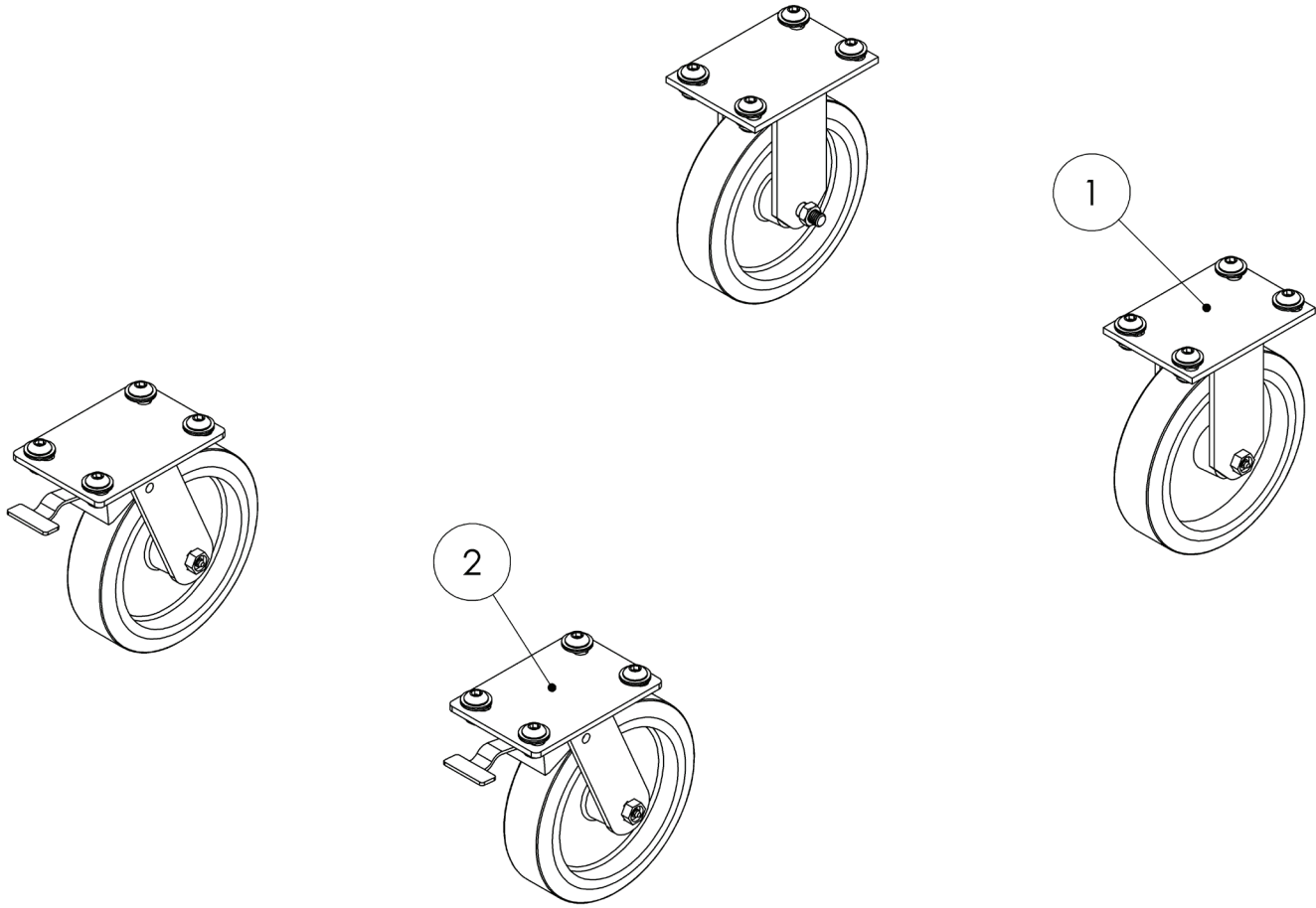

FIGURE 1: Caster Parts

Item #	Part Number	Part Description	Notes	Qty	Superseded By
1	1002103160-KIT	ASM,BASE CASTER,RIGID	SUPERSEDED;	0	143-21-008-50-K
1	143-21-008-50-K	ASM,BASE CASTER,RIGID		2	
2	1002103161-KIT	ASM,BASE CASTER,SWIVEL	SUPERSEDED;	0	WHEE-713-5-KIT
2	143-21-009-50-K	ASM,BASE CASTER,SWIVEL		2	
2	WHEE-713-5-KIT	WHL,8X2 GREY,W/FORK TOTAL LOCK	143-21-009-50-K MAY BE SUBSTITUTED	2	

1.2 | CASTER SUBPARTS

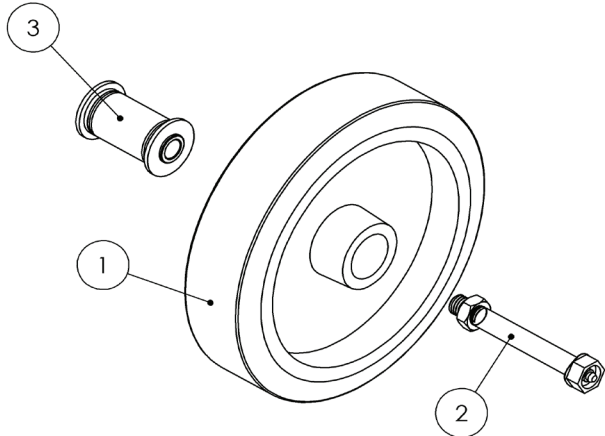

FIGURE 2: Caster Subparts

Item #	Part Number	Part Description	Notes	Qty	Superseded By
1	WHEE-706	WHL,8X2,GREY NM BORE 1.25		1	
2	WHEE-002-2	WHL,AXLE KIT 0.5X3.25		1	
3	WHEE-002-1	WHL,BEARING KIT,0.5 X 2.0 AXLE		1	

1.3 | BRAKE SUBPARTS

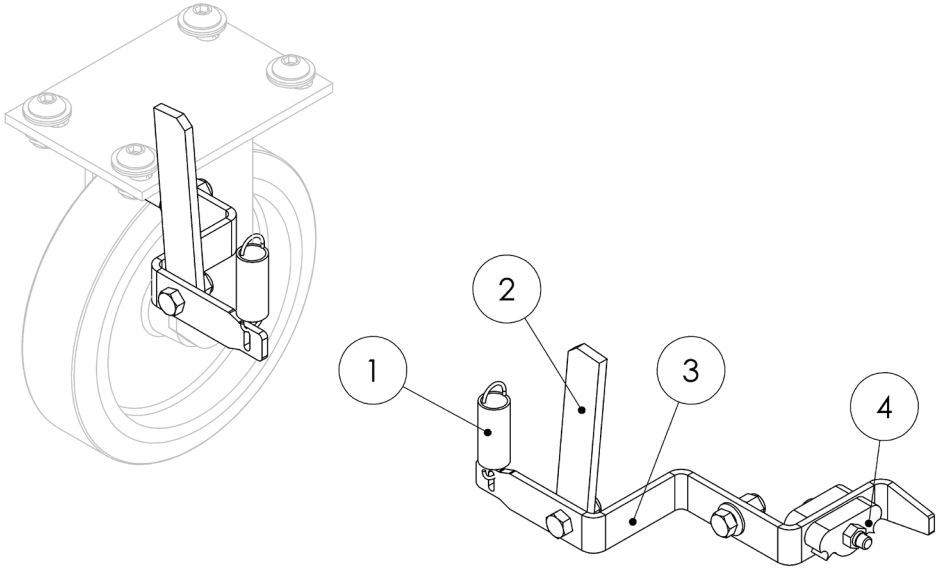

FIGURE 3: Brake Subparts

Item #	Part Number	Part Description	Notes	Qty	Superseded By
1	HARD-690	SPRING,EXT 2.69 X .75,OD		2	
2	143-01-023-02	BASE,BRAKE ACTUATOR		2	
3	143-01-016-02	BASE,BRAKE LEVER		2	
4	143-01-028-02	BASE,BRAKE CAM		4	

## 1.4 | PUMP SUBPARTS

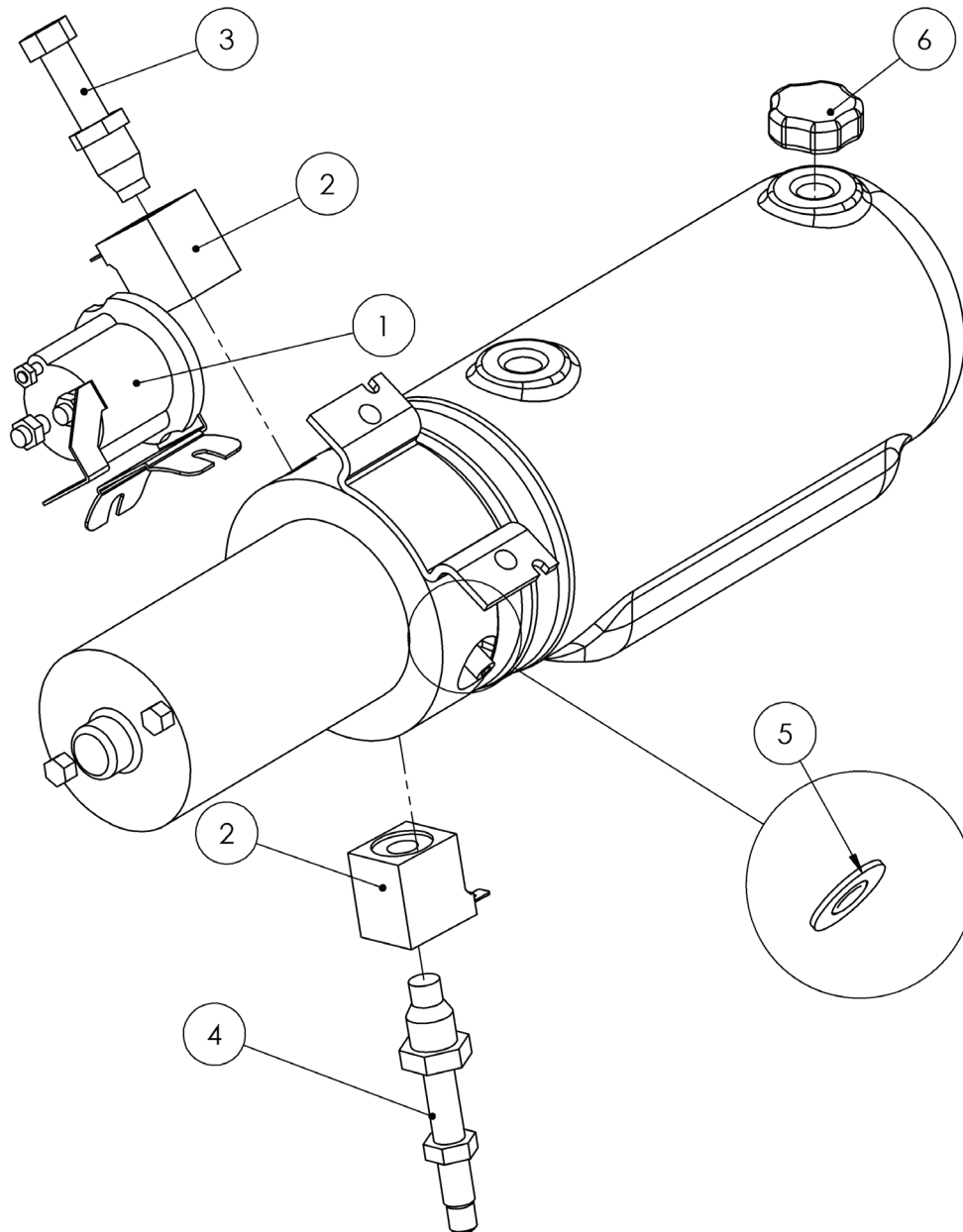

FIGURE 4: Pump Subparts

Item #	Part Number	Part Description	Notes	Qty	Superseded By
1	HYDR-674	SOLENOID,12V,GROUNDED,SPST		1	
2	HYDR-673	COIL,10V		2	
3	HYDR-665	VALVE,NO,2W/2P,#8,UP		1	
4	HYDR-007-2E-5	VALVE,NC,2W/2P,#8,DWN,PULL,DEL		1	
5	HYDR-667	WASH,0.38 ID,0.75 OD,PRES SEAL		1	
6	HYDR-042	PUMP RESERVOIR CAP		1	



## 1.5 | MISCELLANEOUS BASE PARTS

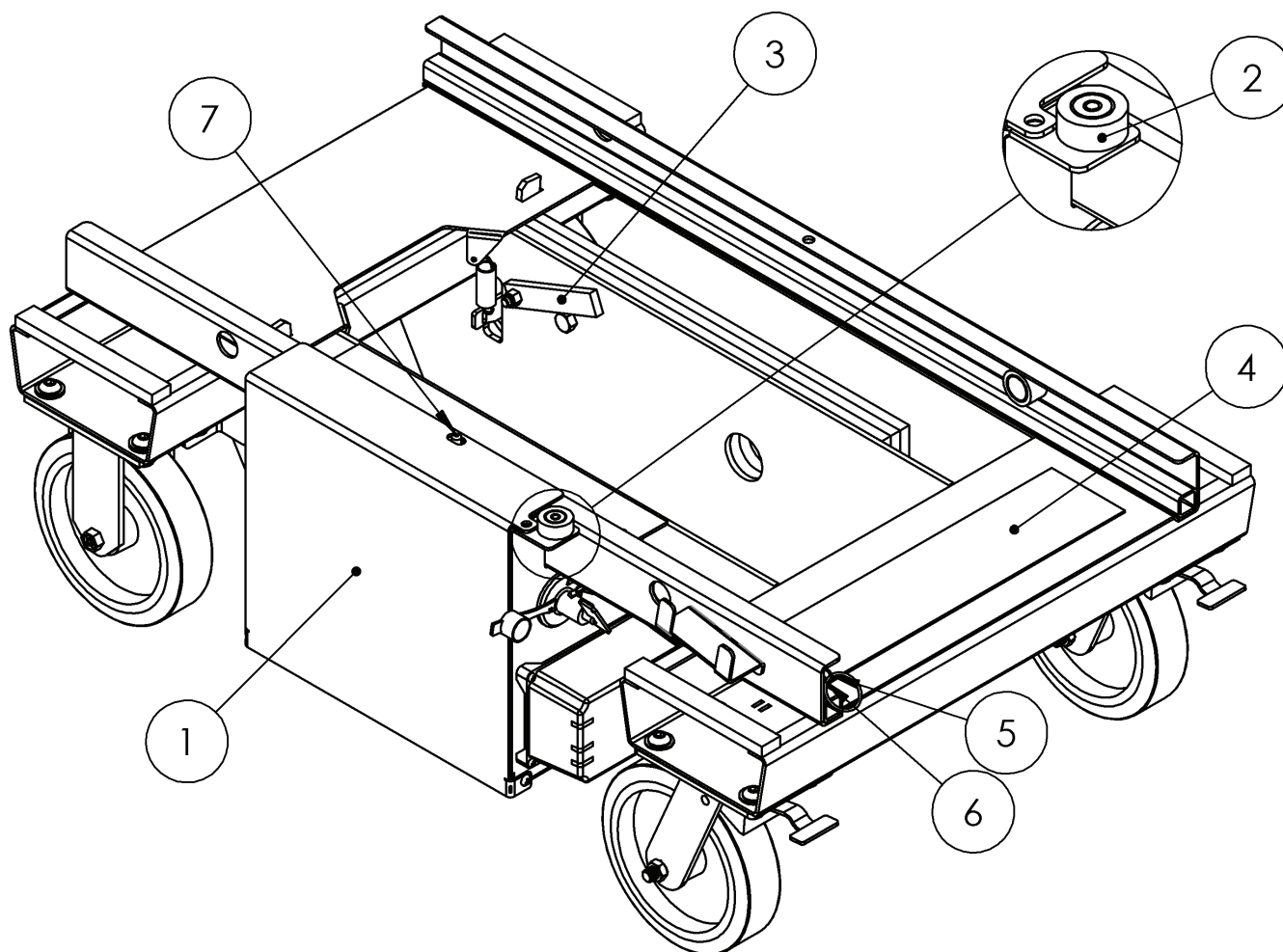

FIGURE 5: Miscellaneous Base Parts

Item #	Part Number	Part Description	Notes	Qty	Superseded By
1	143-05-001-01	COVER,SIDE (BATT.)	STANDARD WHITE	1	
1	143-05-001-16	COVER,SIDE (BATT.)	RED	1	
2	HARD-086	LEVEL,BUBBLE		1	
3	143-01-021-02	BASE,ML CHOCK		2	
4	MISC-031-06-KIT	ANTI-SLIP TAPE,4.00,16.00 LENG		1	
5	HARD-644-03	26/36 LOW FRICTION CABLE		1	
6	HARD-651	1.40 ID,RING		1	
7	HARD-067	0.38SNAP BUTTON,SINGLE END		1	



Item #	Part Number	Part Description	Notes	Qty	Superseded By
1	143-01-025-50	CABLE,6GA,RED,26,R/R,.38 EYES		1	
2	143-21-004-D-50	ASM,CONTROL UPR	D04-10000-D04-10023	1	
2	143-21-004-D-51	ASM,CONTROL UPR	E04-10000-E04-10346	1	
2	144-21-010-55	ASM,CTL UPR HB-P3.6	E04-10347-E04-19999	1	
2	144-21-075-52	ASM,CTL UPR HB-P527	D04-10024-D04-19999	1	
6	ELEC-047-6	BATTERY,12V,GR24 AGM		1	
7	ELEC-123-5	SWITCH,LIMIT,ROT LVR,NO/NC PO		1	
8	ELEC-633-2	SWITCH,BATT DISCONNECT		1	
9	ELEC-634C	TERMINAL COVER (RED)		1	
10	ELEC-634D	TERMINAL BOOT (BLACK)		3	
11	ELEC-641-002	CABLE,6GA,BLACK,12,B/B		1	
12	ELEC-641E	CABLE,6GA,BLK,22,B/B,.38 EYES		1	
13	ELEC-670-2	FUSE 20 AMP AGC	HB-P3.6 & HB-P527 D04-10000-10023	1	
14	ELEC-670-6	FUSE 30 AMP,PCS		2	
15	ELEC-746	CHARGER,12V		1	
16	ELEC-959	FUSE, 20A ATC	HB-P527: D04- 10024-D04-19999	1	
17	HARD-684	BATTERY STRAP,VELCRO		1	
18	ELEC-636-6	CORD,IEC AC WIRE/IEC C13,12.0		1	
19	ELEC-639-1	CORD,NEMA 515/IEC C13,12.0		1	
20	WD-143-20-001-51	WD,HB-P3.6	HB-P3.6; WIRING DIAGRAM	1	
20	WD-143-20-001-50	WD,HB-P527	D04-10000-D04-10023; WIRING DIAGRAM	1	
20	WD-143-20-002-50	WD,HB-P527	D04-10024-D04-19999; WIRING DIAGRAM	1	
21	WS-143-20-001-50	ELEC SCH,HB-P527	D04-10000-D04-10023; ELECTRICAL SCHEMATIC	1	
21	WS-144-20-002-50	ELEC SCH,HB-P	D04-10024-D04-19999; ELECTRICAL SCHEMATIC	1	
21	WS-144-20-001-51	ELEC SCH,HB-P4.5/5.0	E04-10000-E04-10346; ELECTRICAL SCHEMATIC	1	
21	WS-143-20-001-51	ELEC SCH,HB-P3.6	E04-10347-E04-19999; ELECTRICAL SCHEMATIC	1	

2.2 | UPPER CONTROL PARTS

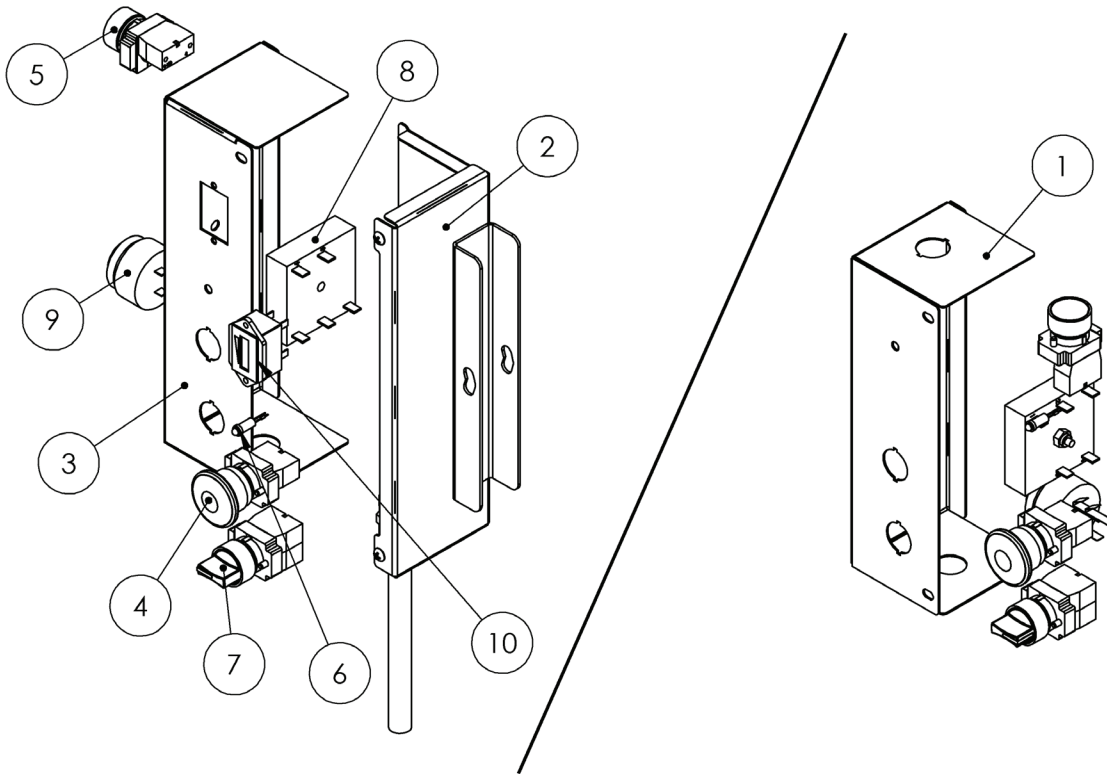

FIGURE 7: Upper Control Parts

Item #	Part Number	Part Description	Notes	Qty	Superseded By
1	143-03-001-01	RAIL,CTL PANEL UPR		1	
2	144-03-004-01	RAIL,CTL BOX MNT		1	
3	144-03-007-01	RAIL,CTL PANEL UPR		1	
4	ELEC-071-KIT	EMERGENCY STOP BUTTON		1	
5	ELEC-602-KIT	BUTTON,PUSH GREEN		1	
6	ELEC-636	LED, RED		1	
7	ELEC-002A-KIT2	SWITCH,ROTARY MOMENTARY,3-POS		1	
8	ELEC-632	RELAY,TIME DELAY		1	
9	ELEC-635	ALARM,SLOW PULSE		1	
10	ELEC-610-5	METER,VOLT,12V		1	
11	WD-144-21-010-55	WD,UPR CTL HB-P3.6	E04-10000-E04-10346; WIRING DIAGRAM	1	
11	WD-143-21-004-51	WD,UPR CTL HB-P3.6	E04-10347-E04-19999; WIRING DIAGRAM	1	
11	WD-143-21-004-50	WD,UPR CTL HB-P527	D04-10000-D04-10023; WIRING DIAGRAM	1	
11	WD-144-21-075-52	WD,UPR CTL HB-P527	D04-10024-D04-19999; WIRING DIAGRAM	1	

## 2.3 | ENABLE SWITCH SUBPARTS

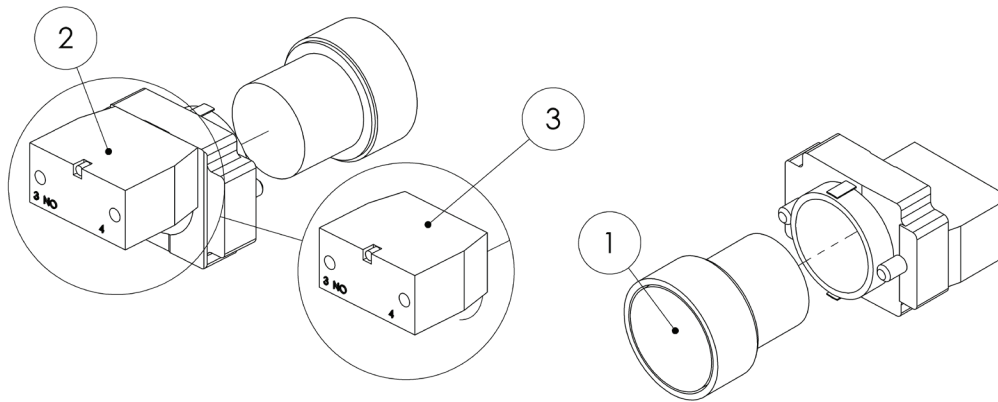

FIGURE 8: Enable Switch Subparts

Item #	Part Number	Part Description	Notes	Qty	Superseded By
1	ELEC-602	BUTTON,PUSH GREEN		1	
2	ELEC-871	CONTACT BLOCK,NO W/BASE		1	
3	ELEC-603	CONTACT BLOCK,NO		1	

## 2.4 | E-STOP SWITCH SUBPARTS

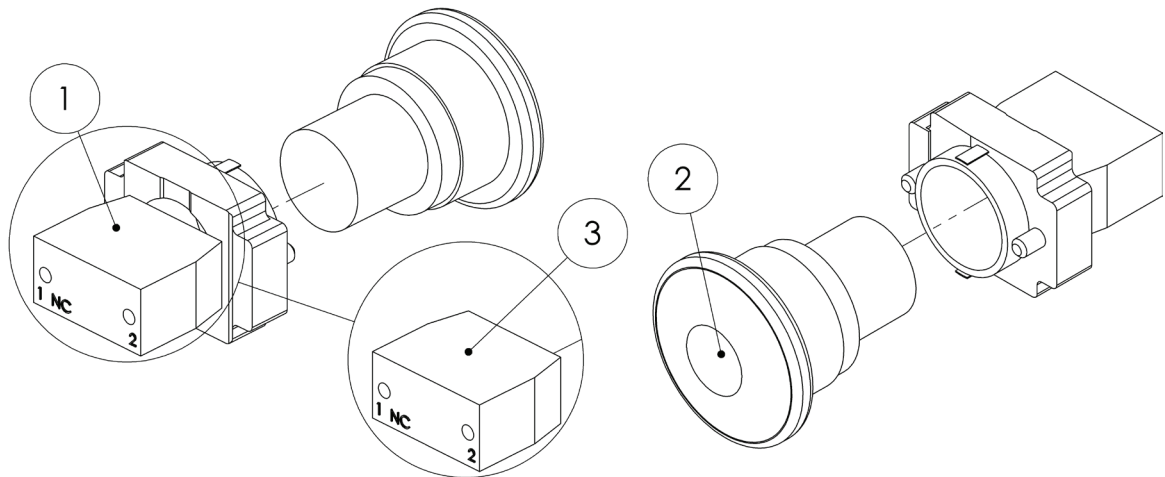

FIGURE 9: E-Stop Switch Subparts

Item #	Part Number	Part Description	Notes	Qty	Superseded By
1	ELEC-872-KIT	CONTACT BLOCK,NC W/BASE		1	
2	ELEC-071	BUTTON,PUSH/PULL RED E-STOP		1	
3	ELEC-072	CONTACT BLOCK,NC		1	

2.5 | MASTER POWER SWITCH SUBPARTS

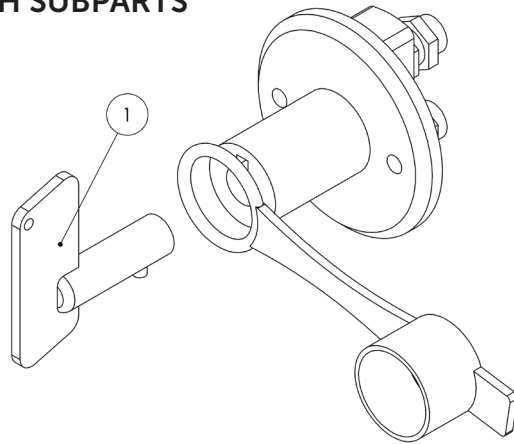

FIGURE 10: Master Power Switch Subparts

Item #	Part Number	Part Description	Notes	Qty	Superseded By
1	ELEC-633-3	SWITCH LEVER,BATT DISCONNECT		1	

2.6 | UP/DOWN SWITCH SUBPARTS

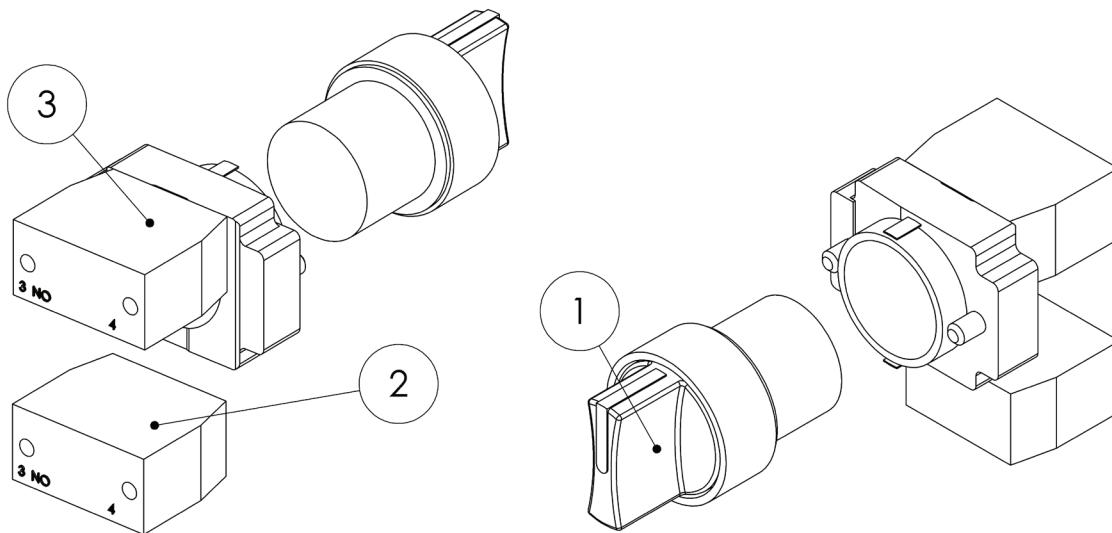

FIGURE 11: Up/Down Switch Subparts

Item #	Part Number	Part Description	Notes	Qty	Superseded By
1	ELEC-002A	SWITCH,ROTARY MOMENTARY,3-POS		1	
2	ELEC-603	CONTACT BLOCK,NO		1	
3	ELEC-871-KIT	CONTACT BLOCK,NO W/BASE		1	

---

THIS PAGE WAS INTENTIONALLY LEFT BLANK

# SECTION 3 | SCISSORS

## 3.1 | SCISSORS PARTS

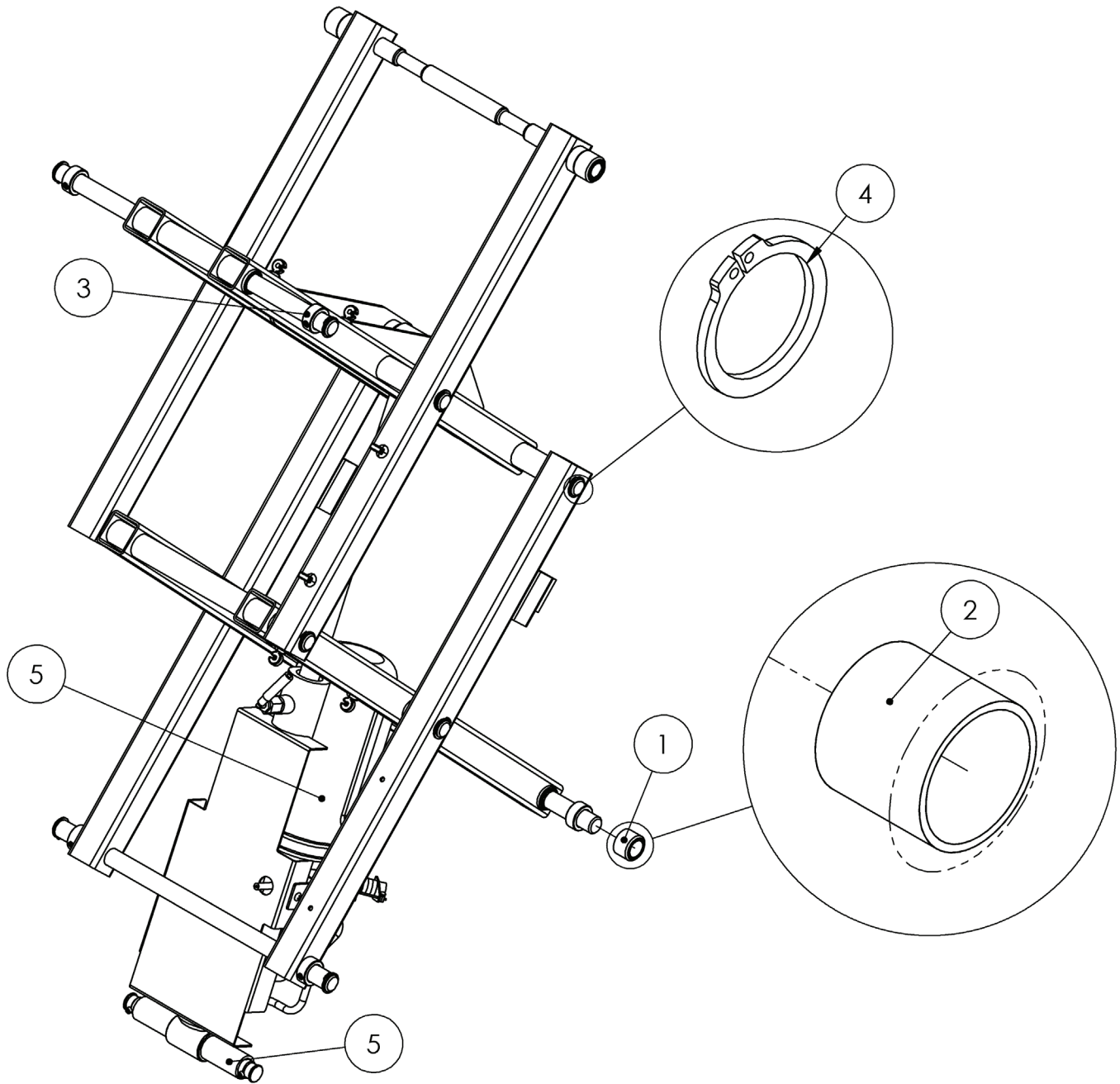

FIGURE 12: Scissors Parts



---

Item #	Part Number	Part Description	Notes	Qty	Superseded By
1	143-21-023-50-K	ASM,ROLLER,1.00 W/DU		1	
2	HARD-001-2	1.00X1.00 SLEEVE BEARING,PTFE		4	
3	143-10-001-02	SET COLLAR,1.0 ID		8	
4	HARD-021	1.00 RETAINING RING,EXT		18	
5	143-21-005-51-K	ASM,CYL & PUMP		1	

---

3.2 | PUMP & CYLINDER SUBPARTS

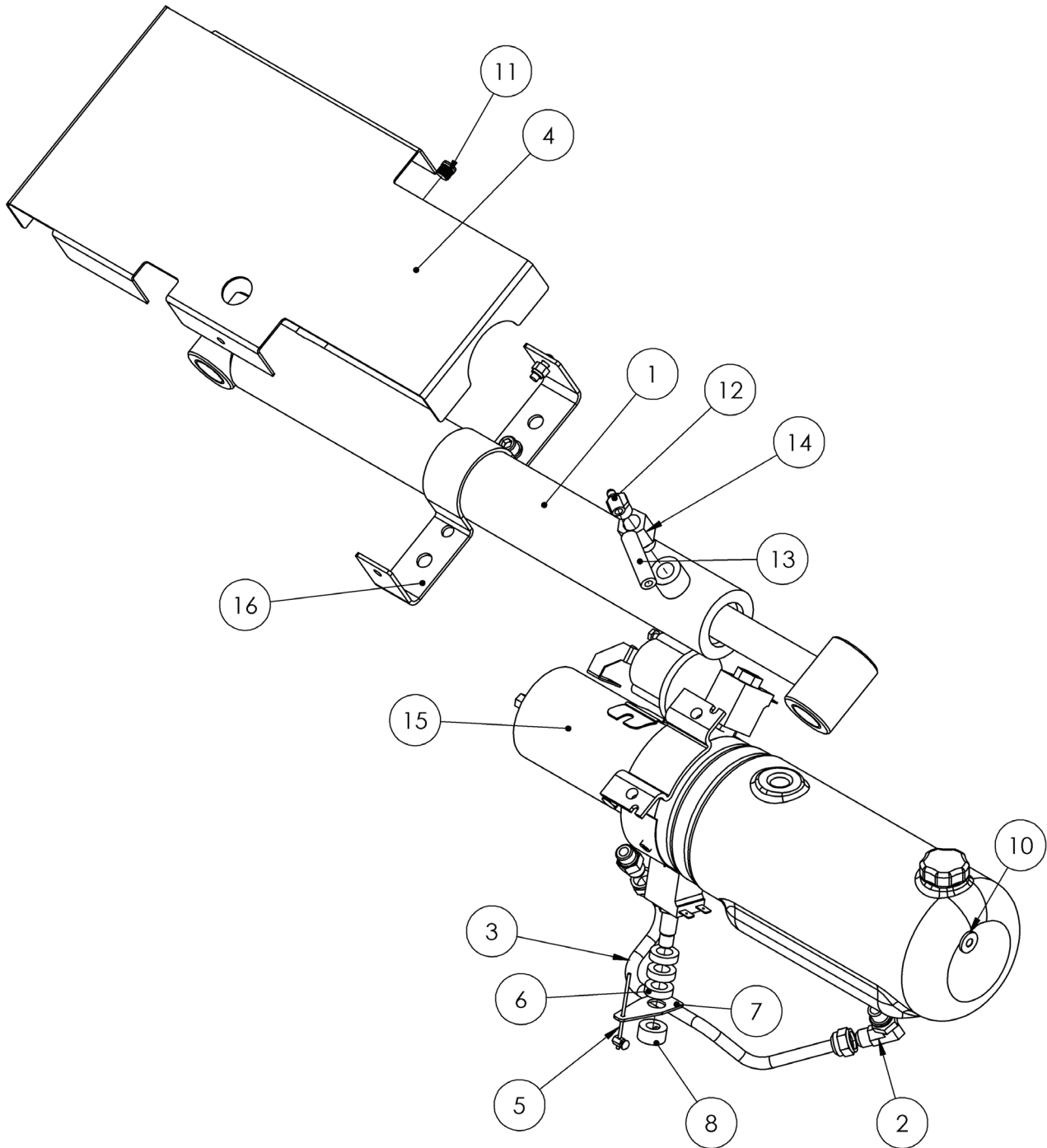

FIGURE 13: Cylinder Subparts

Item #	Part Number	Part Description	Notes	Qty	Superseded By
1	HYDR-002	CYL,26.1,18 STROKE,2.0 BORE		1	
2	HYDR-035	FITTING,ELB,JICM9/16-SAEORM#6		1	
3	HYDR-600-9	PIPE ASM,HYDR LINE		1	
4	143-05-003-01	COVER,PUMP		1	
5	HARD-644-03	26/36 LOW FRICTION CABLE		1	
6	WHEE-605-P	0.50X0.89X0.25 SPACER		3	
7	LAS-M115	SCISSOR,PLATE E-DOWN ACT		1	
8	HARD-650	0.44X0.88X0.44 SHAFT COLLAR		1	
9	HYDR-032	HYDRAULIC OIL	NOT AVAILABLE AS A REPLACEMENT PART. REPLACE WITH FLOMITE #150, DEXRON II, MOBIL-DTE 2 OR EQUIVALENT 32 WEIGHT IMPLEMENT OIL.	1	
10	HYDR-681	GROMMET,FLUID		1	
11	HARD-669	PLUG,SAEORM #4,HEX SOCKET 3/16		1	
12	HYDR-019	FITTING,ELB,NPTM 3/8-1/4 PUSH		1	
13	HYDR-022-3	LOW PRESSURE HOSE		1	
14	HYDR-682	FITTING,STR,NPTF 3/8-SAEORM#6		1	
15	HYDR-050-8	PUMP,12VDC,0.073,0.42,1.5		1	
16	143-02-014-01	SCISSOR,CYL MNT CLAMP		1	

# SECTION 4 | PLATFORM & RAILS

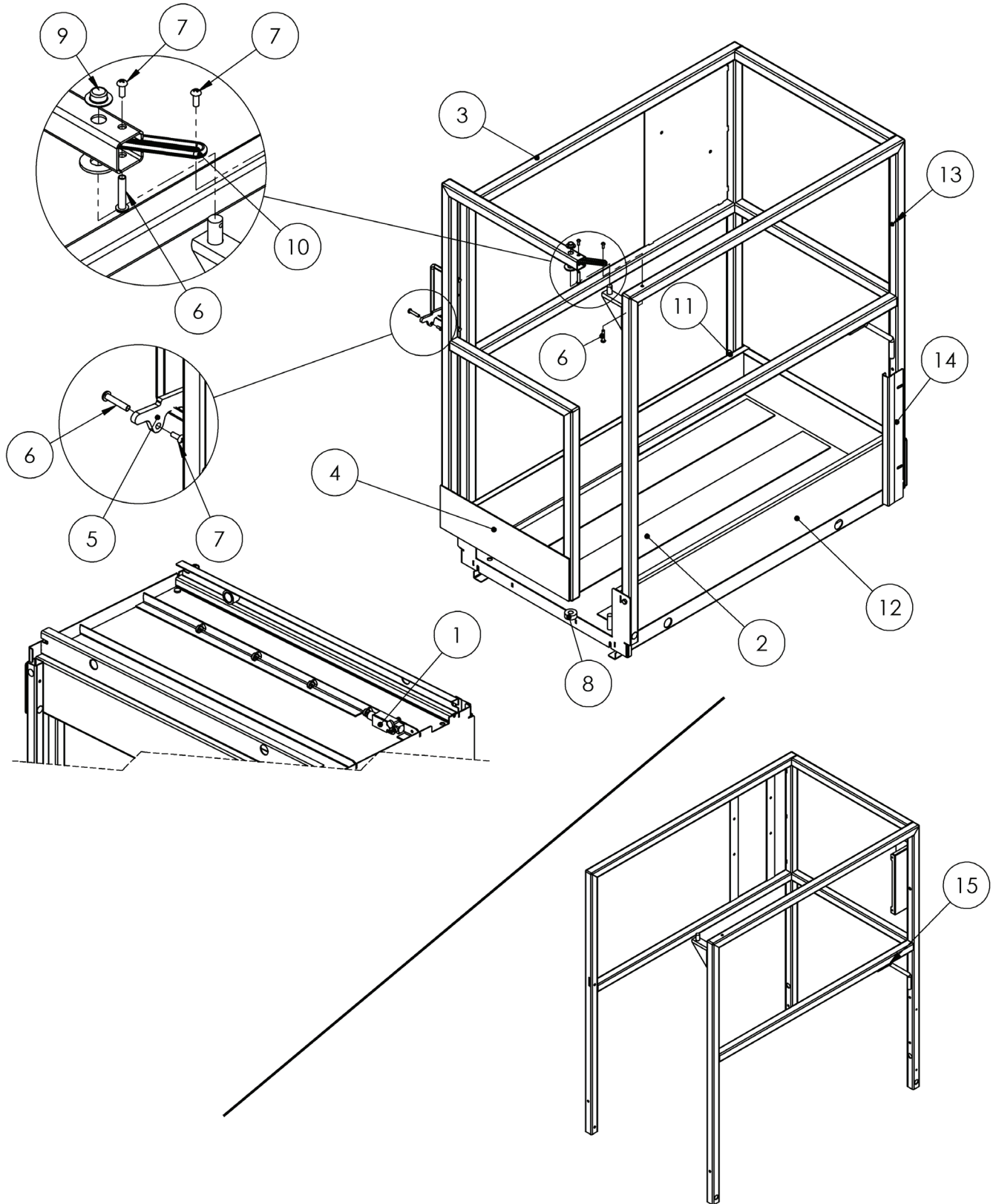

FIGURE 14: Platform & Rails

Item #	Part Number	Part Description	Notes	Qty	Superseded By
1	ELEC-123-5	SWITCH,LIMIT,ROT LVR,NO/NC PO		1	
2	MISC-031-05-KIT	ANTI-SLIP TAPE,4.00,37.50 LENG		3	
3	143-03-006-01	RAIL,WLDMNT	D04-10024-19999 E04-10347-E04-19999; STANDARD YELLOW	1	
3	143-03-006-16	RAIL,WLDMNT	D04-10024-19999 E04-10347-E04-19999; RED	1	
4	143-03-008-01	RAIL,GATE	STANDARD YELLOW	1	
4	143-03-008-16	RAIL,GATE	RED	1	
5	1000307601	RAIL,GATE LATCH		1	
6	HARD-649	0.25 X 1.25 BARREL SCRW,10-24		3	
7	SCREW-1100	10-24 X 0.50 PAN HEAD SCRW		3	
8	143-04-007-04	SPACER,.5ID,1.25OD, 0.5 THK		1	
9	HARD-656-1	QUICK NUT-1/2 ROD		1	
10	HARD-606-2	ORING,0.25 X 5		1	
11	HARD-645	PLUG,0.69 DIA,BLACK		8	
12	143-04-001-01	PF,WLDMNT	STANDARD YELLOW	1	
12	143-04-001-16	PF,WLDMNT	RED	1	
13	HARD-067-2	0.31 SNAP BUTTON,DOUBLE END		1	
14	144-03-008-01	PF,WIRE BRACKET	D04-10024-D04-19999 E04-10347-E04-19999	1	
15	143-03-006-G-01	RAIL, WLDMNT	D04-10000-D04-10023 E04-1000-E04-10346; STANDARD YELLOW	1	
15	143-03-006-G-16	RAIL, WLDMNT	D04-10000-D04-10023 E04-1000-E04-10346; RED	1	

# SECTION 5 | DECALS

## 5.1 | DECALS-ANSI/CSA

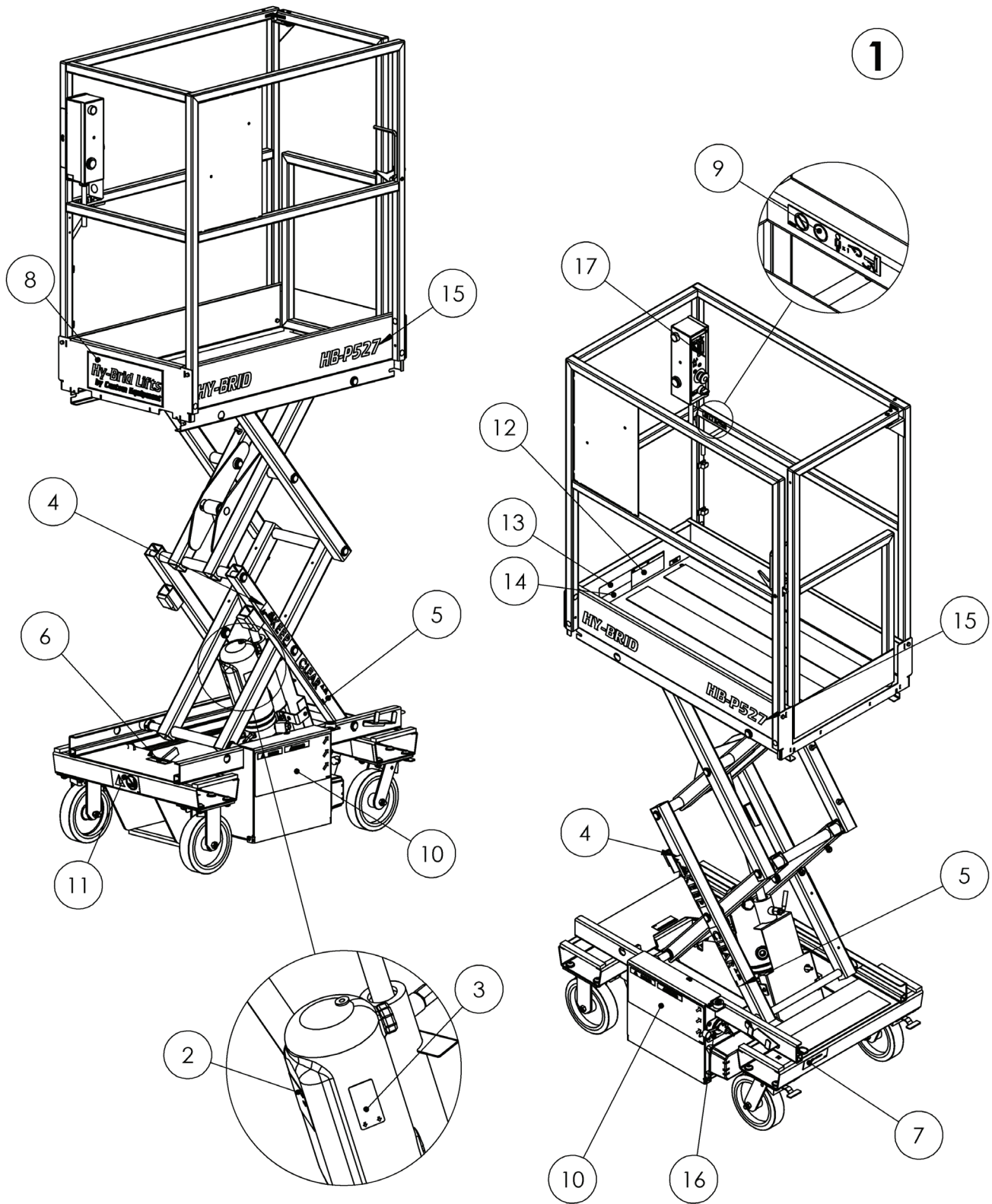

FIGURE 15: Decals-ANSI/CSA

Item #	Part Number	Part Description	Notes	Qty	Superseded By
1	143-21-006-50-K	DECALS,HB-P527		1	
2	DE674	DECAL,HYDR FLUID		1	
3	DE673	DECAL,HYDR FLUID		1	
4	DE727	DECAL,KEEP		2	
5	DE728	DECAL,CLEAR		2	
6	DE600E-14	DECAL,MAINT LOCK		1	
7	DE600E-29	DECAL,E-DOWN	SUPERSEDED;	0	DE751
7	DE751	DECAL,E-DOWN CABLE		1	
8	DE601	DECAL,LOGO HY-BRID	SUPERSEDED;	0	DE821
8	DE821	DECAL,LOGO HY-BRID		1	
9	DE613	DECAL,LANYARD ATTACHMENT		1	
9	DE746	DECAL,LANYARD ATTACHMENT	SUPERSEDED;	0	DE746
10	DE666	DECAL, LWR		1	
11	DE675	DECAL,NO FORK		1	
12	DE706	DECAL,UPR HB		1	
13	DE726	DECAL,CAPACITY,500#,1PI,WO/SO		1	
14	DE730	DECAL,OL ALARM		1	
15	DE603-14	MODEL# DECAL-HB-P527		2	
16	DE760	DECAL,E-STOP HANDLE		1	
17	DE669	DECAL, CONTROL UPR	D04- 10000-D04-10023	1	
17	DE738	DECAL, CONTROL UPR	D04- 10024-D04-19999	1	

5.2 | DECALS-CE

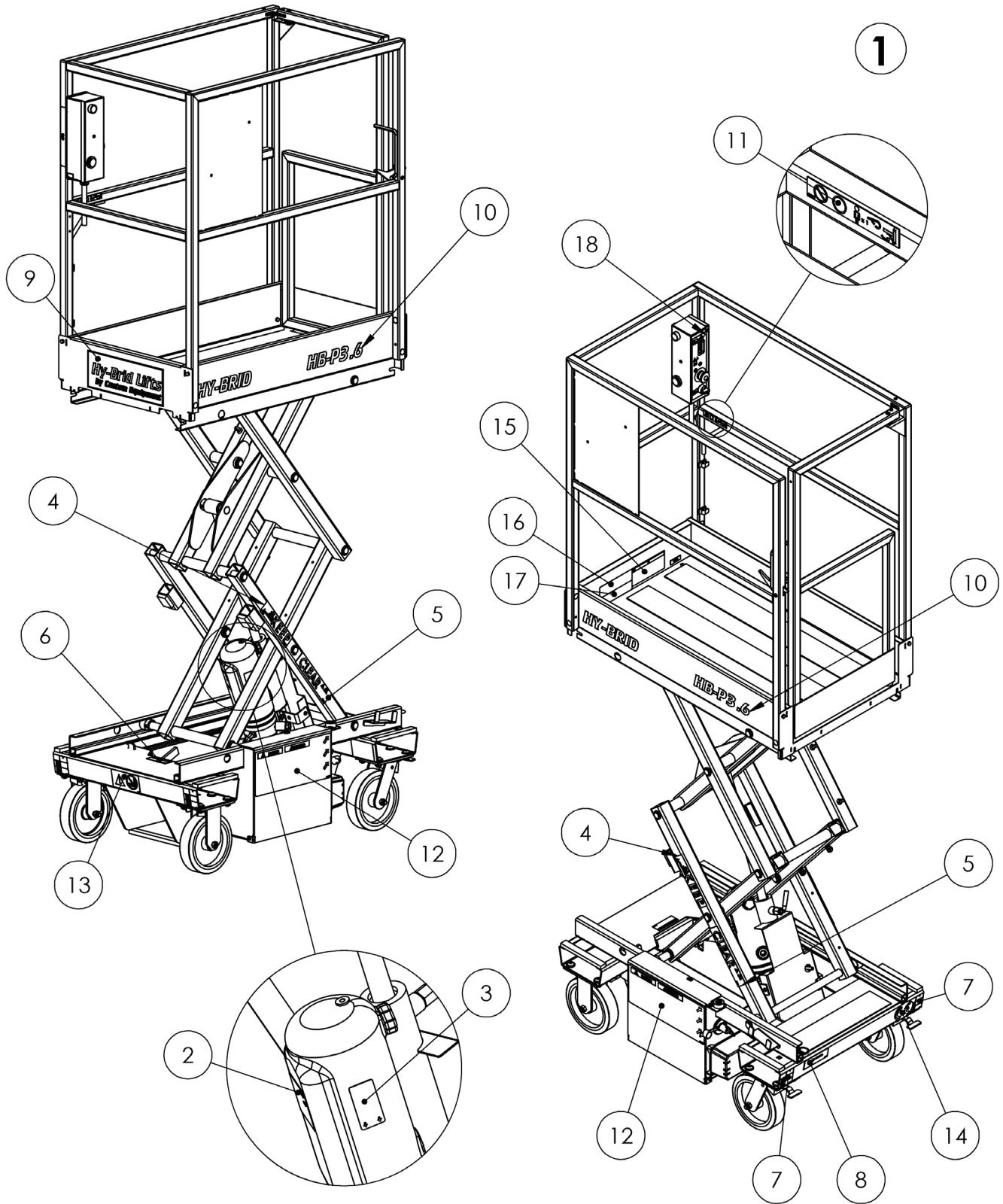

FIGURE 16: Decals-CE



Item #	Part Number	Part Description	Notes	Qty	Superseded By
1	143-21-006-51-K	DECALS,HB-P3.6	KIT	1	
2	DE674	DECAL,HYDR FLUID		1	
3	DE673	DECAL,HYDR FLUID		1	
4	DE727	DECAL,KEEP		2	
5	DE728	DECAL,CLEAR		2	
6	DE600E-14	DECAL,MAINT LOCK		1	
7	DE600E-24F	DECAL,WHEEL LOAD HB-P3.6		4	
8	DE600E-29	DECAL,E-DOWN	SUPERSEDED;	0	DE751
8	DE751	DECAL,E-DOWN CABLE		1	
9	DE601	DECAL,LOGO HY-BRID	SUPERSEDED;	0	DE821
9	DE821	DECAL,LOGO HY-BRID		1	
10	DE603-5	MODEL# DECAL-HB-P3.6		2	
11	DE613	DECAL,LANYARD ATTACHMENT	SUPERSEDED;	0	DE746
11	DE746	DECAL,LANYARD ATTACHMENT		1	
12	DE666	DECAL, LWR		1	
13	DE675	DECAL,NO FORK		1	
14	DE718	DECAL,CE		1	
15	DE706	DECAL,UPR HB		1	
16	DE726	DECAL,CAPACITY,500#,1P,I,WO/SO		1	
17	DE730	DECAL,OL ALARM		1	
18	DE669	DECAL, CONTROL UPR	E04-10000-E04-10346	1	
18	DE738	DECAL, CONTROL UPR	E04-10347-E04-19999	1	

# SECTION 6 | OPTIONS & MISCELLANEOUS

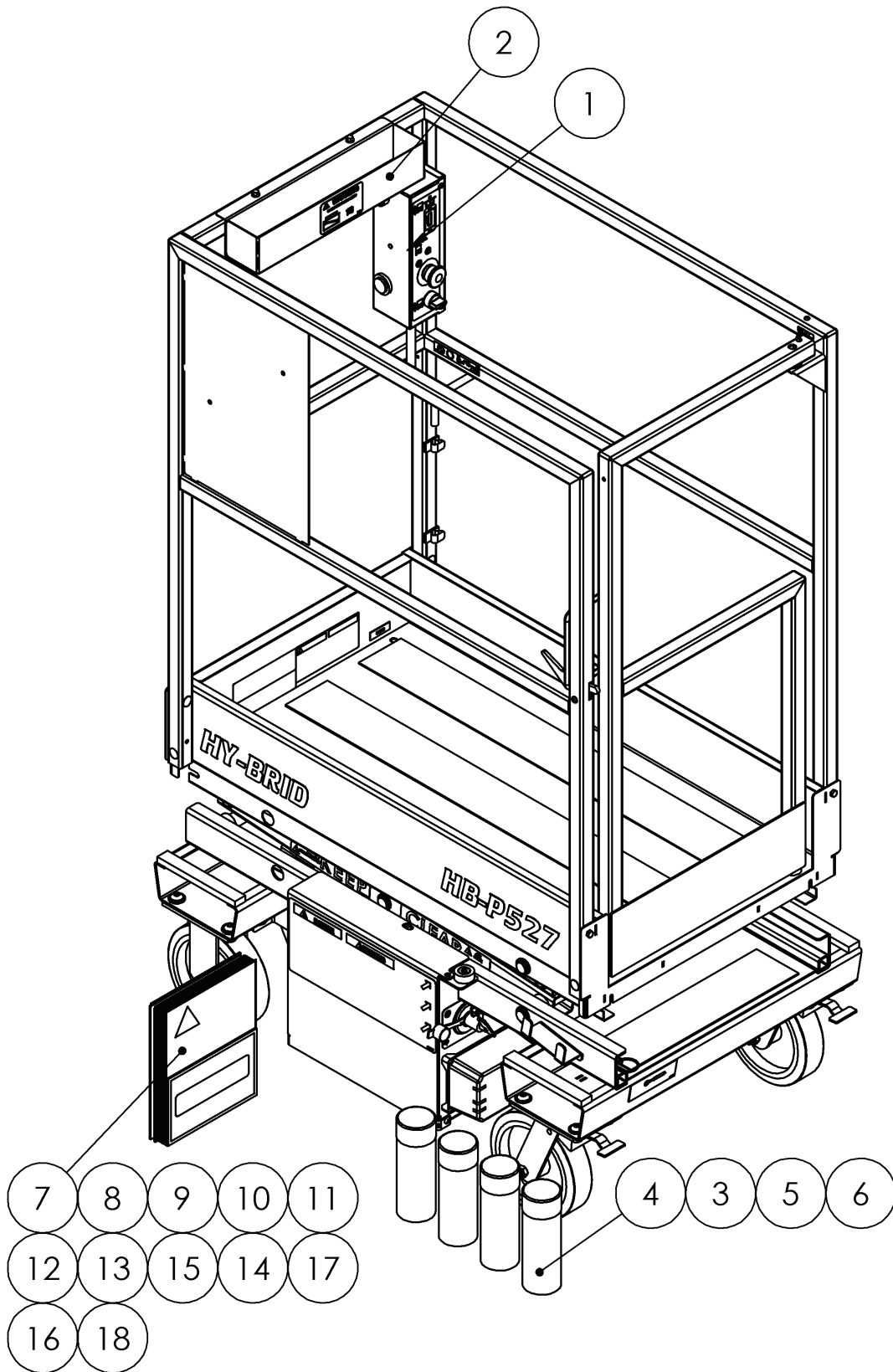

FIGURE 17: Options & Miscellaneous

Item #	Part Number	Part Description	Notes	Qty	Superseded By
1	144-21-019-50-K	MOTION ALARM,HB-P827/1027 S1		1	
2	144-21-021-50-K	TOOL TRAY, HB		1	
3	MISC-016	PAINT,RED TOUCH-UP SPRAY		1	
4	MISC-624	PAINT,WHITE TOUCH-UP SPRAY		1	
5	MISC-625	PAINT,YELLOW TOUCH-UP SPRAY		1	
6	MISC-627	PAINT,GREEN TOUCH-UP SPRAY		1	
7	MISC-601-1	MANUAL OF RESPONSIBILITY A92.3		1	
8	MISC-600	MANUAL,AERIAL PF		1	
9	SUPO-644	DOCUMENT,CE DECL HB-P3.6		1	
10	SUPO-642	MANUAL,OP,HB-P527	D04-10000-D04-10023	1	
11	SUPO-642E	MANUAL,OP,HB-P3.6	E04-10000-E04-10346	1	
12	SUPO-643	MANUAL,MAINT,HB-P527	D04-10000-D04-10023	1	
13	SUPO-643E	MANUAL,MAINT,HB-P3.6	E04-10000-E04-10346	1	
14	SUPO-723	MANUAL,OP,HB-P527	D04-10024-D04-19999	1	
15	SUPO-724	MANUAL,MAINT,HB-P527	D04-10024-D04-19999	1	
16	SUPO-725	MANUAL,OP,HB-P3.6	E04-10347-E04-19999	1	
17	SUPO-726	MANUAL,MAINT,HB-P3.6	E04-10347-E04-19999	1	
18	SUPO-731	MANUAL,PARTS HB-P527/3.6		1	
19	SUPO-676	DOCUMENT,CSA DECL HB-P527		1	
20	HS-HB-P3.6	HYD SCH,HB-P3.5/527		1	

# **HY-BRID LIFTS™**

BY CUSTOM EQUIPMENT INC

---

Push-Around Aerial Work Platform  
Parts Manual  
HB-P527/HB-P3.6

---

© 2017 Custom Equipment, Inc.  
2647 Highway 175  
Richfield, WI 53076  
U.S.A.  
Tel. +1-262-644-1300  
Fax: +1-262-644-1320  
[www.hybridlifts.com](http://www.hybridlifts.com)  
[Service@Customequipmentlifts.com](mailto:Service@Customequipmentlifts.com)

"Hy-Brid Lifts" is a trademark of Custom Equipment, Inc.  
These machines comply with specified ANSI, CSA & EN 280  
requirements

Revision Date: August 2017

Printed In The USA