

# Hy-Brid Lifts®

## OPERATIONS & SAFETY MANUAL

PUSH-AROUND AERIAL WORK PLATFORM

SUPO 642E  
JUNE 2014



---

## HB-P3.6

---

SERIES 1



# FOREWORD

Original instructions written in English

The purpose of this Maintenance Manual is to provide qualified service personnel with information for servicing and maintaining Hy-Brid Lifts. All information in this manual must be read and understood before any attempt is made to service this machine.



**THE OPERATION AND SAFETY MANUAL MUST BE READ AND UNDERSTOOD PRIOR TO OPERATING THE MACHINE.**

- The user/operator should not accept operating responsibility until the manual has been read and understood as well as having operated the lift under supervision of an experienced and qualified operator.
- Because the manufacturer has no direct control over machine application and operation, proper safety practices are the responsibility of the user and all operating personnel.



**ANY MODIFICATION ON THIS MACHINE WITHOUT THE EXPRESS WRITTEN CONSENT OF THE MANUFACTURER IS PROHIBITED.**

Fall protection notice: The guardrail system around the perimeter of the platform is the fall protection system for push-around elevating work platforms per the EN 280:2001 Standard. It is prohibited to use an Aerial Work Platform manufactured by Custom Equipment, Inc. With any portion—or all—of the guardrails removed. Lanyard anchorage points on this type of equipment are not required to conform to the applicable standard. However, if anchorage points for lanyard attachments are required by site authorities or other regulations, the anchorage points on all equipment manufactured by Custom Equipment, Inc. Are recommended to be used for work positioning restraints of personnel only. Lanyard lengths are to be determined by operator/owner to restrict the operator to the confines within the guardrail system.

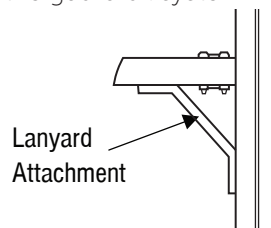

**USE OF FALL ARREST SYSTEMS ATTACHED TO ANCHORAGE POINTS ON EQUIPMENT MAY CAUSE MACHINE TO TIP, RESULTING IN SERIOUS INJURY OR DEATH.**

# TABLE OF CONTENTS

---

SECTION 1   PRODUCT DESCRIPTION .....	6
1.1   GENERAL.....	6
1.2   EC DECLARATION OF CONFORMITY .....	6
1.3   MACHINE SPECIFICATIONS .....	6
SECTION 2   SAFETY .....	8
2.1   SAFETY SYMBOLS.....	8
2.2   GENERAL RULES AND PRECAUTIONS .....	8
2.3   SAFETY FEATURES .....	9
2.4   SAFETY INDICATORS & INTERLOCKS .....	9
2.5   SAFETY CONTROLS .....	9
2.6   MAINTENANCE LOCK .....	10
2.7   SAFETY GUIDELINES .....	11
SECTION 3   DECALS .....	12
3.1   DECAL LOCATION .....	12
3.2   DECAL MEANING OR DESIGNATION.....	13
3.3   DECAL SYMBOLS .....	13
SECTION 4  TRANSPORT HANDLING & STORAGE.....	17
4.1   PRELIMINARY UNPACKING INSTRUCTIONS AND DEALER INSPECTION .....	17
4.2   STORAGE .....	17
4.3   TRANSPORTATION .....	17
4.4   LIFT/TIE DOWN POINTS .....	17
4.5   FORK LIFT POCKETS .....	18
4.6   TRANSPORT HANDLING & STORAGE .....	18
SECTION 5   OPERATION .....	19
5.1   BEFORE YOU OPERATE.....	19
5.2   CONTROLS.....	19
5.3   SHUT DOWN.....	20
5.4   ELEVATING AND LOWERING.....	21
5.5   DAILY MAINTENANCE.....	21
5.6   CHARGING THE BATTERY.....	21
5.7   PRE-START INSPECTION CHECKLIST .....	24

# INDEX OF FIGURES

---

FIGURE 1: EMERGENCY LOWERING VALVE .....	10
FIGURE 3: MAINTENANCE PIN USE.....	10
FIGURE 2: EMERGENCY LOWERING INSTRUCTIONS.....	10
FIGURE 4: MAINTENANCE PIN STORAGE .....	10
FIGURE 5: REAR BRAKES.....	17
FIGURE 6: TIE DOWN POINTS .....	17
FIGURE 7: CENTER OF GRAVITY .....	18
FIGURE 8: UPPER CONTROLS.....	19
FIGURE 9: MASTER POWER SWITCH ON .....	19
FIGURE 10: BUBBLE LEVEL AND BRAKE LOCATION.....	20
FIGURE 11: KEY REMOVED .....	20
FIGURE 12: PADLOCK .....	20
FIGURE 13: BATTERY CHARGER LED DISPLAY .....	22

## REVISION LOG:

REV A .....	MAY 2013
REV B .....	MAY 2013
REV C.....	JULY 2013
REV D (ECO 1839).....	JULY 2014

# SECTION 1 | PRODUCT DESCRIPTION

## 1.1 | GENERAL

Custom Equipment's Hy-Brid Scissor Lift is an aerial work platform designed to be safe and reliable. The purpose of the machine is to elevate personnel, along with their necessary tools and materials. The machine is intended for indoor use (no wind load). Manufacturer approval is required for any use other than the intended use.

## 1.2 | EC DECLARATION OF CONFORMITY

We hereby declare that the above mentioned machine has been assessed, tested and approved in accordance with the requirements of the Machinery Directive 2006/42/EC using the document EC Community Legislation on Machinery and taking guidance from EN280:2001 + A2:2009 with the following exceptions:

Clause 5.4.1.2b: Warning is provided as required by 2006/42/EC clause 4.2.2

An EC type-examination was tested internally by the manufacturer, in accordance with EN280:2001 + A2:2009 and 2006/42/EEC Annex VII, as listed in Article 12 and Annex IV, item 17 of directive 2006/42/EEC, which excludes devices with a platform height of less than three meters.

Model Numbers: HB-P3.6

Machine Type: Mobile Elevating Work Platform

Applicable Harmonised Standard: EN280:2001 + A2:2009

Manufacturer

Custom Equipment, Inc.

2647 Hwy 175

Richfield, WI 53076

U.S.A.

Phone: +1-262-644-1300

Fax: +1-262-644-1320

www.hybridlifts.com

## 1.3 | MACHINE SPECIFICATIONS

DIMENSIONS	U.S.A.	METRIC
Working Height (maximum)	11.81 ft	3.6 m
Platform Height (maximum)	5.25 ft	1.77 m
Stowed Height	63.59 in	1.62 m
Ground Clearance	2.5 in	0.06 m
Overall Width	26.6 in	0.67 m
Overall Length	41 in	1.04 m
Platform	22 in x 37 in	0.56 m x 0.94 m
Guard Rail Height	43.83 in	1.1 m
Toe Board Height	6 in	0.15 m
Platform Entrance	20.28 in	0.52 m
Step Height	12.58	0.32 m
Wheel Base	33.11 in	0.84 m
Wheel Track	22.13 in	0.56 m
Turning Radius (Inside)	Zero	Zero
Tire Size (Solid, Non-Marking)-Front	8 in	20.3 cm

Tire Size (Solid, Non-Marking)-Rear	8 in	20.3 cm
<b>RATED LOAD</b>		
Lift Capacity (Evenly Distributed):	500 lbs / 1 Person	226.8 kg / 1 Person
Horizontal/Manual Force	45 lb	200 N
Machine Weight (Unloaded) (Approx.)	575 lb	261 kg
Minimum Wheel Load-Contact Pressure	115 psi	792.89 kPa = 8.09 kg/cm <sup>2</sup>
Maximum Wheel Load-Contact Pressure	215 psi	1482.37 kPa = 15.12 kg/cm <sup>2</sup>
Minimum Machine Loading-Floor Pressure	75.92 psf	3.65 kPa = 0.04 kg/cm <sup>2</sup>
Maximum Machine Loading-Floor Pressure	141.94 psf	6.76 kPa = 0.07 kg/cm <sup>2</sup>
<b>ENVIRONMENTAL LIMITATIONS</b>		
Wind	No windy conditions / Indoor use only	
Rated Slope	Level Surface	Level Surface
Temperature	-4°F to -104°F	-20°C to 40°C
Vibration	8.2 ft / s <sup>2</sup> max	2.5 m / s <sup>2</sup> max
Sound	86 dB Normal Use	86 dB Normal Use
<b>POWER SYSTEMS</b>		
Lift/Lower Speed	10 / 15 se	10 / 15 sec
Hydraulic Pressure (max)	650 psi	4482 kPa
Hydraulic Fluid Capacity	1.69 quarts	1.6 L
Power System-Voltage	12V DC	12V DC
Batteries-Deep Cycle Marine	12V, Group 24 AGM	12V, Group 24 AGM

# SECTION 2 | SAFETY

---

## 2.1 | SAFETY SYMBOLS



“DANGER” indicates an imminently hazardous situation, which, if not avoided, will result in death or serious injury.

**FAILURE TO FOLLOW THIS WARNING WILL CAUSE DEATH OR PERSONAL INJURY.**

---



“WARNING” indicates a potentially hazardous situation, which, if not avoided, could result in death or serious injury.

**FAILURE TO FOLLOW THIS WARNING MAY CAUSE DEATH OR PERSONAL INJURY.**

---



“CAUTION” indicates a potentially hazardous situation which, if not avoided, could result in minor or moderate injury or damage to equipment.

**FAILURE TO FOLLOW THIS WARNING MAY CAUSE INJURY OR DAMAGE TO EQUIPMENT**

## 2.2 | GENERAL RULES AND PRECAUTIONS

An operator of any type of work platform is subject to certain hazards that cannot be protected by mechanical means. It is therefore essential that operators be competent, careful, physically and mentally fit and thoroughly trained in safe operation of this machine.

Although Custom Equipment, Inc. Conforms to specified ANSI & OSHA, it is the responsibility of the owner to instruct operators with the safety requirements made not only by Custom Equipment, Inc., but by the various safety boards in your area, as well as additional requirements set forth by ANSI and OSHA. If you come across a situation that you think might be unsafe, stop the platform and request further information from qualified sources before proceeding.



**NEVER REACH BETWEEN SCISSORS LINKS OR PROP UP PLATFORM.**





**WHEELS EXTENDING BEYOND THE SIDES OF THE BASE  
MAY OCCUR IN TIGHT TURNING SITUATIONS.**

## 2.3 | SAFETY FEATURES

- Puncture-proof Wheels.
- Guardrails--1.1 m height with 15 cm kick plates.
- Non-slip Deck.
- Entrance Gate.
- Automatic Parking Brake.
- Free Descent Protection. A pressure compensated flow control valve is installed in the hydraulic circuit to prevent the platform from descending in case of a ruptured hydraulic hose. The platform is hydraulically locked with a check valve and has controlled descent when valve activates.
- Decals. Danger, Caution, and Warning decals are displayed at various locations on this unit.
- Key Switch Security. A key switch is required to prevent unauthorized use.

## 2.4 | SAFETY INDICATORS & INTERLOCKS

### Load Sensing

Movement is inhibited when the load exceeds the rated load and elevating is attempted from the stowed position. When elevating begins, an audible alarm sounds and the overload indicator lights up to indicate that the load control system is functional. If the load is less than rated load, the light and alarm will stop, and elevating may continue. If the rated load is exceeded, the alarm and light will continue and the platform will not elevate. Remove the excess load before continuing operation.

### Armguard

When lowering the platform, the platform will stop when the ends of the scissors are 50mm apart for 3 seconds. Release the enable button. Look around all sides of the scissors to check for persons at risk. Then continue lowering the platform. If elevating platform less than 50mm, the lift will not descend due to the armguard feature. Elevate the platform higher before lowering, or use the manual override in case of emergency.

### Descent / Motion Alarm

An audible alarm sounds when the machine is lowering.

## 2.5 | SAFETY CONTROLS

### Descent - Manual Override

For manually lowering the scissors, a manual down valve on the cylinder is provided. To lower the scissors, pull the cable located near the rear of the machine.

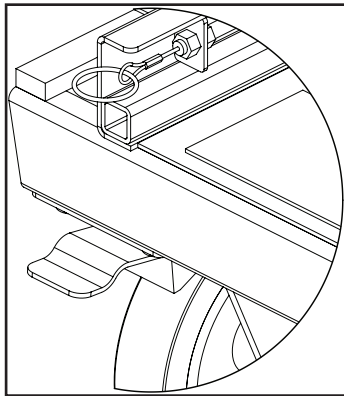

FIGURE 1: Emergency Lowering Valve

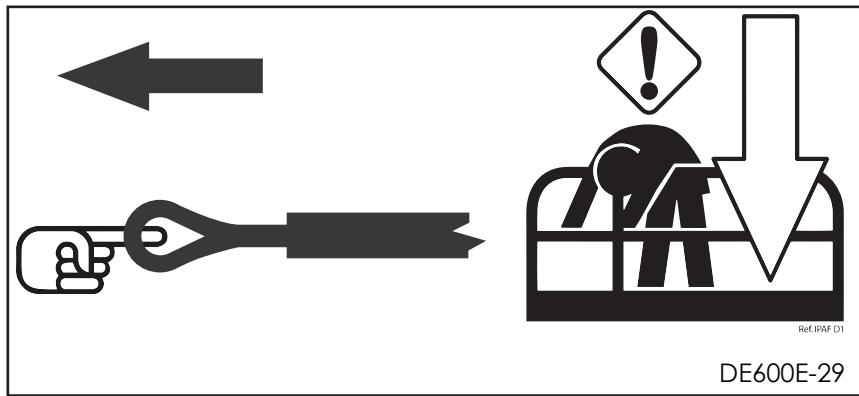

FIGURE 2: Emergency Lowering Instructions



**IF PLATFORM SHOULD FAIL TO LOWER, DO NOT ATTEMPT TO CLIMB DOWN THE BEAM ASSEMBLY. SERIOUS INJURY MAY RESULT. HAVE AN EXPERIENCED OPERATOR USE THE EMERGENCY LOWERING PROCEDURE TO SAFELY LOWER THE PLATFORM.**



**BRACE YOURSELF AND SECURE OBJECTS ON THE PLATFORM DURING OPERATION OF THE MACHINE.**

## 2.6 | MAINTENANCE LOCK

The maintenance lock must be placed into position whenever the machine is being serviced in a partially raised position. Serious injury and/or death could result if maintenance lock is not used properly.

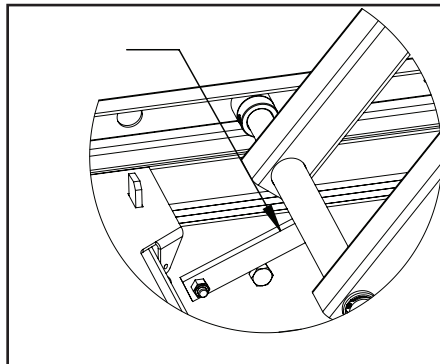

FIGURE 3: Maintenance Pin Use

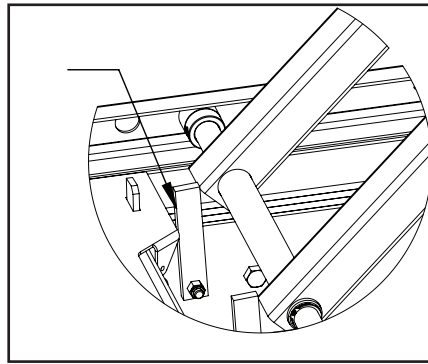

FIGURE 4: Maintenance Pin Storage

## 2.7 | SAFETY GUIDELINES

### Only qualified operators may operate this unit.

- All operators must read and understand the Operation and Safety Manual. They must understand all decals and warning labels on unit.
- Do not work on platform if your physical condition is such that you feel dizzy or unsteady in any way.
- Do not neglect/misuse machine. Report any misuse of equipment to proper personnel.
- Prevent unauthorized use; when unit is not in use, remove key.
- It is recommended all personnel on unit wear approved personal protective equipment (PPE), i.e. head gear.

### Use machine only for purposes for which it was intended.

- Lift should never be used as a crane.
- Do not exceed the load capabilities of the platform.
- Distribute load evenly over platform floor area.
- Never use unit as electrical grounds for arc welding.
- Do not override any hydraulic, mechanical, or electrical safety devices.

### Check job site for unsafe working conditions.

- Watch out for others. Keep others clear of operating platform. Never allow others to pass under a raised platform or position the platform over someone.
- Avoid contact with fixed (buildings, etc.) or moving (vehicles, cranes, etc.) objects. Check work area for overhead obstructions or possible hazards.
- Follow any applicable national traffic regulations.
- Use indoors only. Lift is not designed for windy conditions or electrical storms.
- Unit must be on hard level surface before elevating. Do not operate on incline or uneven surface.
- You must maintain a clearance between any part of the machine, or its load, and any electrical line or apparatus. Follow local power line clearance regulations.
- You must maintain a clearance between any part of the machine, or its load, and any electrical line or apparatus. Follow local power line clearance regulations.



**DO NOT OPERATE MACHINE NEAR POWER LINES. THE PLATFORM AND ENCLOSURES ARE NOT INSULATED. EQUIPMENT IS ONLY AS SAFE AS THE OPERATOR.**

- Do not use ladders or scaffolding on the platform to obtain greater height.
- Do not enter or exit platform while machine is in motion.
- Never mount or dismount a raised platform.
- Make sure entry gate is secured before operating machine from the platform.
- Never belt or tie off to an adjacent structure.
- Secure tools and materials.
- Personnel must maintain a firm footing on the platform floor and work only within the platform area.
- Before operation, ensure that the machine is properly serviced.
- Do not use machine if it is not working properly.
- Make sure platform rails and pins are secured.
- Operator shall use the maintenance lock when performing all types of maintenance procedures.
- Do not smoke while charging the battery.

# SECTION 3 | DECALS

## 3.1 | DECAL LOCATION

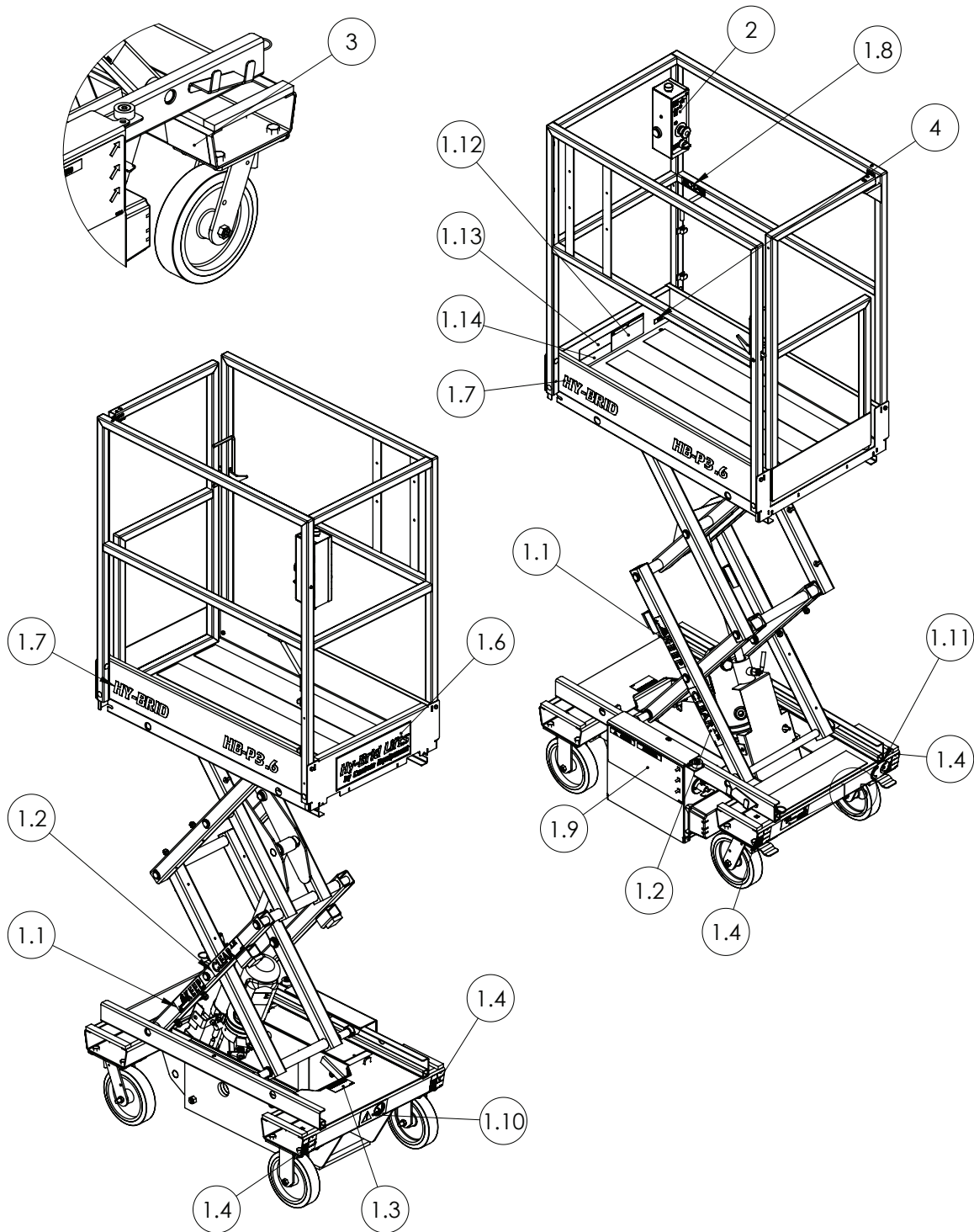









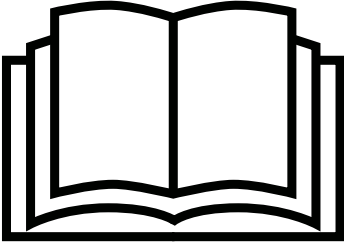

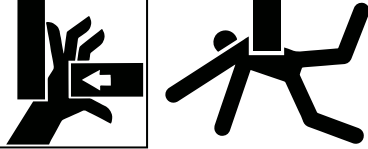
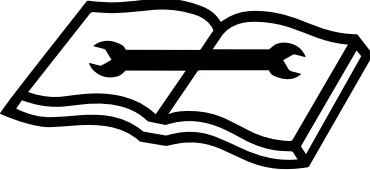

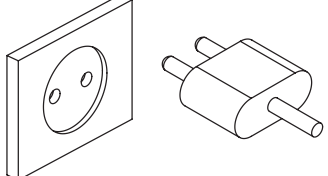
### 3.2 | DECAL MEANING OR DESIGNATION

"ITEM NO."	PART NUMBER	DESCRIPTION	QTY.	UM
1	143-21-006-51	DECALS,HB-P3.6	1	EA
1.1	DE727	DECAL,KEEP	2	EA
1.2	DE728	DECAL,CLEAR	2	EA
1.3	DE600E-14	DECAL,MAINT LOCK(SYMBOLS)	1	EA
1.4	DE600E-24F	DECAL,WHEEL LOAD HB-P3.6	4	EA
1.5	DE751	DECAL,E-DOWN CABLE	1	EA
1.6	DE601	DECAL,LOGO HY-BRID	1	EA
1.7	DE603-5	MODEL# DECAL-HB-P3.6	2	EA
1.8	DE746	DECAL,LANYARD ATTACHMENT	1	EA
1.9	DE666	DECAL, LWR	1	EA
1.1	DE675	DECAL,NO FORK	1	EA
1.11	DE718	DECAL,CE	1	EA
1.12	DE706	DECAL,UPR HB,ZTR,MID	1	EA
1.13	DE726	DECAL,CAPACITY,500#,1P,I,WO/SO	1	EA
1.14	DE730	DECAL,OL ALARM	1	EA
2	DE669	DECAL,CTL UPR	1	EA
3	N/A	SERIAL NUMBER LOCATION	1	EA
4	N/A	SERIAL NUMBER REFERENCE	1	EA

### 3.3 | DECAL SYMBOLS

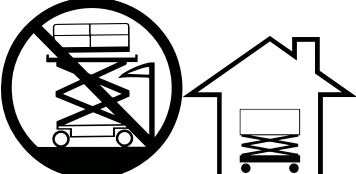
Symbol	Meaning
	<ul style="list-style-type: none"> <li>• No Unauthorized Use</li> <li>• Do not operate this machine unless you have been trained in safe operation.</li> <li>• Training includes complete knowledge of the safety and operating instructions contained in the manufacturer's manual, your employer's work rules, and applicable government regulations.</li> <li>• An untrained operator subjects himself and others to death or serious injury.</li> </ul>

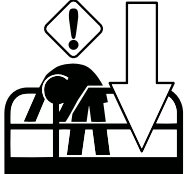
	<ul style="list-style-type: none"> <li>• Read and understand all dangers and warning in the operator’s manual before operating this machine.</li> <li>• Improper use of this machine could cause death or serious injury.</li> <li>• Inspect machine and make sure that it is operating properly, that all name plate and hazard signs are in place and legible, and that the machine is in accordance with the manufacturer’s maintenance requirements contained in the operating and maintenance requirements contained in the operation and maintenance manual and the daily safety checklist.</li> </ul>
	<ul style="list-style-type: none"> <li>• Lanyard anchorage point location: Capacity 1 person</li> <li>• Lanyard anchorage point are for work positioning restraints only, not for fall protection</li> <li>• Use of fall arrest systems attached to anchorage points on mobile equipment may cause machine to tip, resulting in serious injury or death.</li> </ul>
	<ul style="list-style-type: none"> <li>• Crushing Hazard</li> <li>• Do not enter the space beneath the work platform or scissor structure unless the maintenance lock is in place.</li> </ul>
	<ul style="list-style-type: none"> <li>• Refer to Maintenance Manual</li> <li>• Only qualified service personnel may service the machine. Failure to comply with listed safety precautions may result in machine damage, personnel injury, or death.</li> <li>• Replace designated items with manufacturer’s specified equipment only. Failure to use these items may cause instability.</li> </ul>
	<ul style="list-style-type: none"> <li>• Batteries produce explosive gas. Charge batteries in a well-ventilated area.</li> <li>• Do not expose sparks or flames.</li> <li>• Do not smoke while charging battery.</li> </ul>
	<ul style="list-style-type: none"> <li>• Battery Charger Cord</li> </ul>
	<ul style="list-style-type: none"> <li>• Tip Hazard</li> </ul>

	<ul style="list-style-type: none"> <li>• Tip Hazard</li> <li>• Do not elevate platform on a slope</li> </ul>
	<ul style="list-style-type: none"> <li>• Tip Hazard</li> <li>• Do not elevate platform on uneven or soft surfaces.</li> </ul>
	<ul style="list-style-type: none"> <li>• Indoor Use Only: No Wind Load</li> </ul>
	<ul style="list-style-type: none"> <li>• Electrocution Hazard</li> <li>• This machine is not insulated.</li> <li>• Maintain safe clearance from electrical lines and apparatus. You must allow for machine sway, rock or sag and electrical lines swaying.</li> <li>• This machine does not provide protection from contact with or proximity to an electrically charged conductor.</li> <li>• You must maintain a clearance between any part of this machine or its load and any electrical apparatus. Follow local power line regulations.</li> <li>• Death or serious injury will result from contact or inadequate clearance.</li> </ul>
	<ul style="list-style-type: none"> <li>• Emergency Lowering</li> </ul>
	<ul style="list-style-type: none"> <li>• For safety and controlled handling, it is not recommended to move the unit on a slope greater than 5°.</li> </ul>

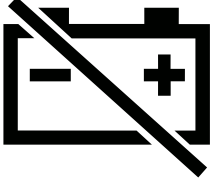
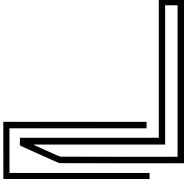
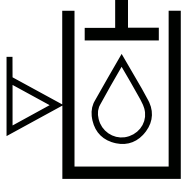
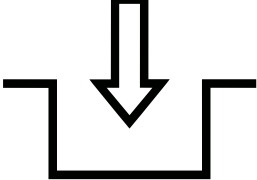
	<ul style="list-style-type: none"><li>• Battery disconnect</li></ul>
	<ul style="list-style-type: none"><li>• Fork Pocket</li></ul>
	<ul style="list-style-type: none"><li>• Hydraulic oil level</li></ul>
	<ul style="list-style-type: none"><li>• Engaging mechanical Action</li></ul>



# SECTION 4 | TRANSPORT HANDLING & STORAGE

## 4.1 | PRELIMINARY UNPACKING INSTRUCTIONS AND DEALER INSPECTION

Maintenance locks must be engaged prior to inspecting or servicing the unit when the platform is extended. Inspect machine for any possible damage during shipment; perform a pre-delivery inspection. See checklist on the Maintenance Manual. Reset emergency stop switch if necessary

## 4.2 | STORAGE

After periods of storage, exposure to extremes of ambient conditions-heat, cold, moisture, dust etc., inspect the machine. Refer to the Pre-Delivery/ Frequent Inspection Checklist in the Maintenance Manual.

## 4.3 | TRANSPORTATION

Lower the work platform to the down position and check entire machine for loose or unsecured items. Remove any loose items from machine.

The machine can be pushed by lifting the brake levers behind each rear wheel. To resume normal operation, make sure both brake levers are down. Do not push at speeds more than 2 mph (0.9 m/s).

Do not attempt to push or tow unit with the brakes applied. Severe gear damage will occur. Towing is not recommended.

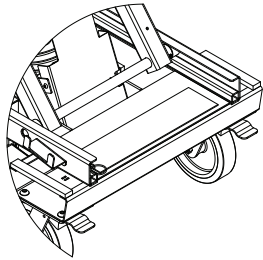

FIGURE 5: Rear Brakes

## 4.4 | LIFT/TIE DOWN POINTS

Lower the work platform to the down position. Turn key switch to off position. For safety and controlled handling, it is not recommended to move the unit on a slope greater than 5°. Check entire machine for loose or unsecured items. Remove any loose items from machine. Apply manual brake lock on rear wheels.

Tie-down points are provided in the front and rear of the machine for securing the machine on a trailer or truck bed for transport between places of use. They may also be used as lift points.

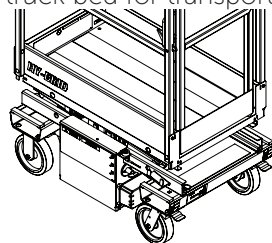
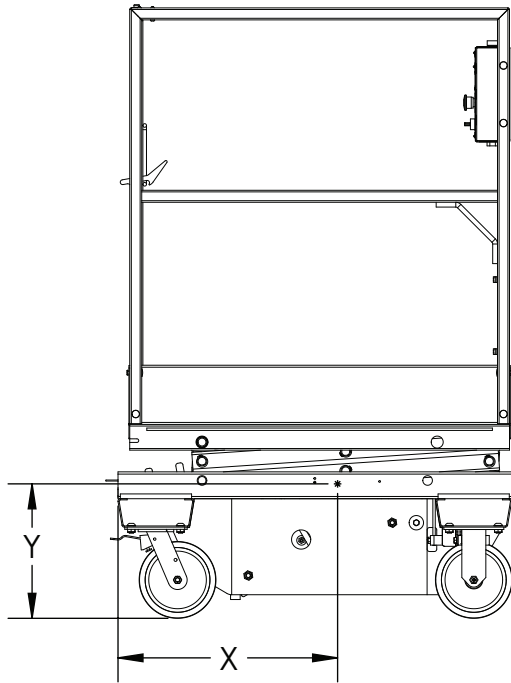

FIGURE 6: Tie Down Points

4.5 | FORK LIFT POCKETS

Fork lift pockets are provided on the side of the unit for loading and unloading. Do not use a forklift underneath the machine from the back. When moving machine with a forklift, do not let machine slide along floor. Bring forklift to a stop and then gently lower the machine.



Center Of Gravity	X Axis	Y Axis
HB-P3.6	54.7 cm	38.3 cm

FIGURE 7: Center of Gravity

# SECTION 5 | OPERATION

## 5.1 | BEFORE YOU OPERATE

Before use each day or at the beginning of each shift, the machine shall be given a visual inspection and functional test. Repairs (if any) must be made prior to operating the machine, as it is critical to ensure safe operation of the machine. A checklist for pre-start inspection can be found in the Daily Maintenance section of this manual.

## 5.2 | CONTROLS

### Platform Controls

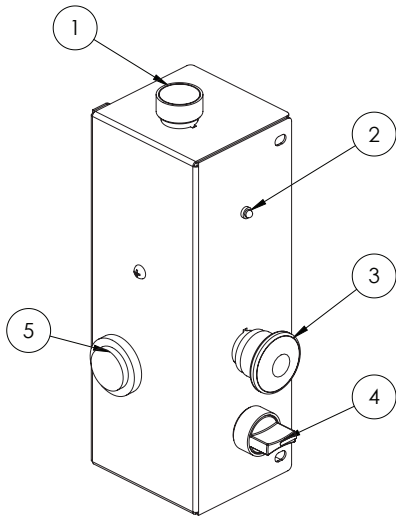

Item	Control/Indicator
1	Lift Enable Button Operation described as follows.
2	Overload LED Lights up indicating overload system active, remains on if overloaded.
3	Emergency Stop Operation described in Safety Controls, (Page <?>).
4	Up / Down Rotary Switch Operation described as follows.
5	Beeper Alarm Alarm sounds on for descent, motion, and overload.

FIGURE 8: Upper Controls

### Master Power Switch

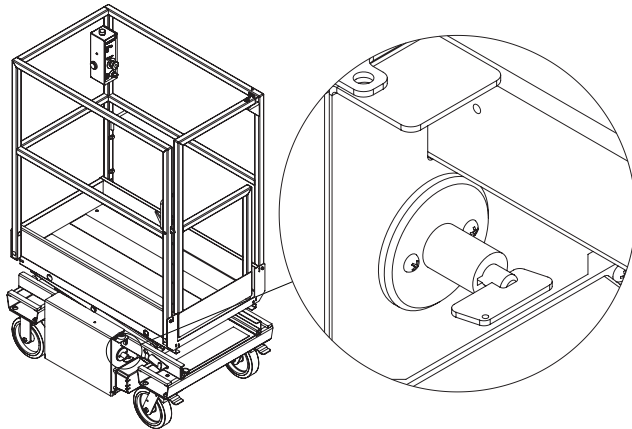

FIGURE 9: Master Power Switch On

- Check that the work area is safe
- It is not recommended to manoeuvre the unit on a slope greater than 5°
- Check that master power switch is in "ON" position
- Machine must be on a hard, level surface before operation. Check that bubble level is centered
- Engage the manual breaks on the rear casters before elevating the platform



**THE OPERATOR MUST BE AWARE OF THE ENVIRONMENT.  
DO NOT RAISE THE PLATFORM IF THE MACHINE IS NOT ON  
A FIRM, LEVEL SURFACE.**

**Bubble Level and Brakes**

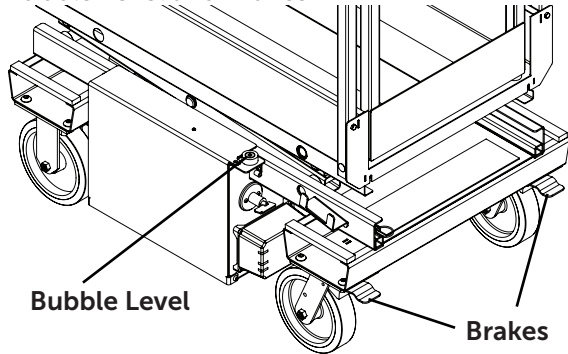

- Enter the work platform in the stowed position using the constant three point method.
- Follow all general rules and precautions stated in this manual.

FIGURE 10: Bubble Level and Brake Location

**5.3 | SHUT DOWN**

- When finished with the machine, place the platform in the stowed position.
- Carefully exit the platform using the constant three point contact method. NEVER JUMP OFF THE PLATFORM
- Park the machine on a level surface.
- Turn master power switch to off position.
- To prevent unauthorized use, remove the key from the master power switch.
- The key may be placed in the manual pouch and the cabinet padlocked to secure the machine in the isolated position.

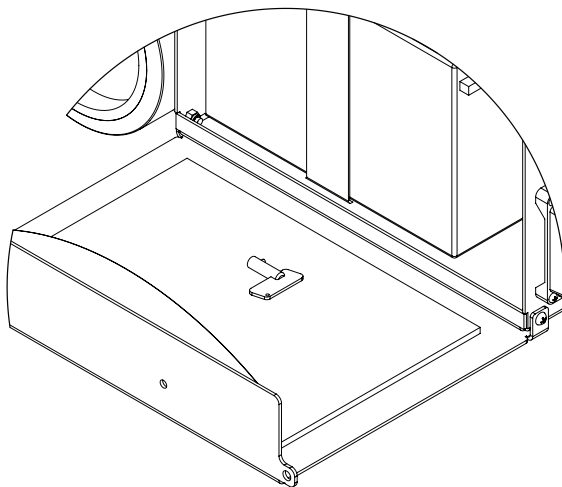

FIGURE 11: Key Removed

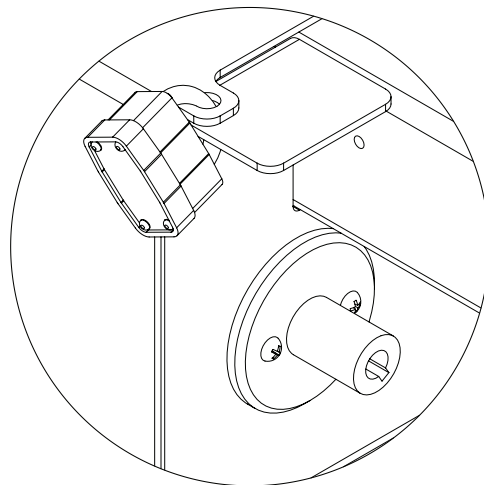

FIGURE 12: Padlock

## 5.4 | ELEVATING AND LOWERING

To raise or lower the platform, press the Elevate / Lower Enable Button. While holding down the Enable Button, rotate and hold the Elevate/Lower switch until the platform is in the desired position.

When lowering the platform, the platform will stop when the ends of the scissors are 50mm apart for 3 seconds. Release the enable. Look around all sides of the scissors to check for persons at risk. Then continue lowering the platform. (See Safety Features, section 2.3 on page <?>).

## 5.5 | DAILY MAINTENANCE

Regular inspection and conscientious maintenance is important for efficient economical operation of this machine. It will help to assure that equipment will perform satisfactorily with a minimum of service and repair. Make checks at the stated intervals or more frequently if required by local operation conditions. A Pre-Start Inspection Checklist is included in this manual. In addition, Pre-Delivery/Frequent and Monthly Checklists are included in a separate Maintenance Manual. Also refer to the Maintenance Manual for replacement part information.



**FAILURE TO PERFORM INSPECTIONS AND PREVENTATIVE MAINTENANCE AT RECOMMENDED INTERVALS MAY RESULT IN THE UNIT BEING OPERATED WITH A DEFECT THAT MAY RESULT IN INJURY OR DEATH OF THE OPERATOR.**

Regular inspection and conscientious maintenance is important to efficient economical operation of this machine. It will help to assure that equipment will perform satisfactorily with a minimum of service and repair. Make checks at the stated intervals or more frequently if required by local operating conditions. A Pre-Start Inspection Checklist is included in this manual.

Additional maintenance for use by trained personnel is included in a separate Maintenance Manual. Refer to the Maintenance Manual for Pre-Delivery/Frequent and Monthly Checklists and replacement part information.

## 5.6 | CHARGING THE BATTERY

This unit is equipped with a deep cycle 12-volt battery. The care and maintenance of your battery has much to do with how well this unit functions. Battery wiring should be checked monthly.

**Note: The surrounding temperature greatly affects the power reserve within a battery.**

Example: A battery that is 100% charged at 80° F (27°C) drops to 65% at 32°F (0°C). At 0°F (-18°C), this battery will drop to 40% efficiency.



**LEAD-ACID BATTERIES GENERATE EXPLOSIVE GASES. KEEP SPARKS AND FLAME AWAY FROM BATTERIES. DO NOT SMOKE WHILE CHARGING.**

Do not operate unit while charging. Shortened battery life will result.

- Park the machine on a level surface.
- Plug charger into AC outlet until charged.
- For best battery life, leave charger plugged in until machine will be used again. The charger will maintain the battery charge.

The charger will not begin the charging cycle on severely discharged batteries. Battery solution is at its proper strength when the battery is manufactured. Use distilled water and keep fluid up to proper level. When required, water should be added to battery after charging, unless water level is below the plates.

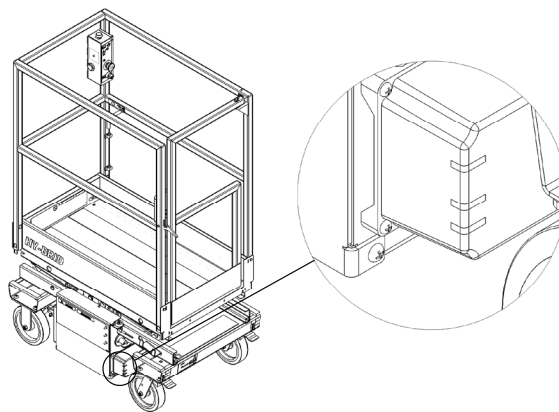
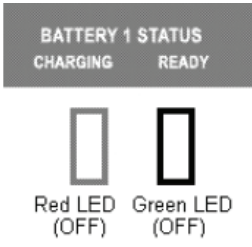
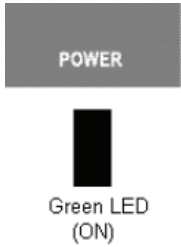
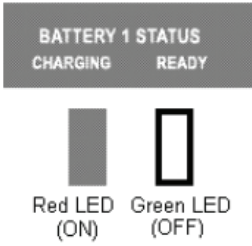
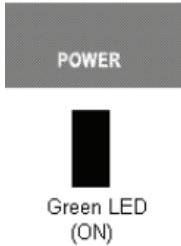

FIGURE 13: Battery Charger LED Display

**Reading the Battery Display**



This display indicates that the power is on but there is no connection to a battery. The charger must see approximately five (5) volts on a battery to deliver D/C current.



This display indicates that power is on and that both outputs are delivering D/C current to the batteries.

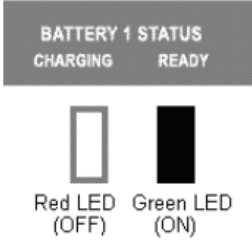
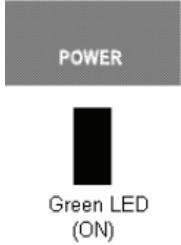

This display indicates that power is on and that the output is finished charging and is in a float maintenance model.

5.7 | PRE-START INSPECTION CHECKLIST



**THIS CHECKLIST MUST BE USED AT THE BEGINNING OF EACH SHIFT OR AFTER EVERY SIX TO EIGHT HOURS OF USE. FAILURE TO DO SO COULD AFFECT THE SAFETY OF THE OPERATOR.**

**MODEL NUMBER: HB-P3.6 SERIAL NUMBER:** \_\_\_\_\_

- Keep inspection records up-to-date.
- Record and report all discrepancies to your supervisor.
- A dirty machine cannot be properly inspected.

Y – Yes/Acceptable    N – No/Unacceptable    R – Repaired

Description	Y	N	R
<b>Visual Inspection</b>			
Check that there are no damaged, dented, or bent structural members.	<input type="checkbox"/>	<input type="checkbox"/>	<input type="checkbox"/>
There are no loose or missing parts.	<input type="checkbox"/>	<input type="checkbox"/>	<input type="checkbox"/>
Check that warning and instructional labels are legible and secure. Ensure that load capacity is clearly marked.	<input type="checkbox"/>	<input type="checkbox"/>	<input type="checkbox"/>
Check the platform rails and safety gate for damage.	<input type="checkbox"/>	<input type="checkbox"/>	<input type="checkbox"/>
Platform and base controls are not missing, damaged, or disconnected.	<input type="checkbox"/>	<input type="checkbox"/>	<input type="checkbox"/>
Electrical cables and wires are not torn, frayed, or disconnected.	<input type="checkbox"/>	<input type="checkbox"/>	<input type="checkbox"/>
Hydraulic hoses are not torn or loose, and there are no leaks. Check that hoses and cables have no worn areas or chafing.	<input type="checkbox"/>	<input type="checkbox"/>	<input type="checkbox"/>
Check the hydraulic fluid level with the platform fully lowered.	<input type="checkbox"/>	<input type="checkbox"/>	<input type="checkbox"/>
Check the tires for damage.	<input type="checkbox"/>	<input type="checkbox"/>	<input type="checkbox"/>
Check that all snap rings are secure in grooves on pivot pins.	<input type="checkbox"/>	<input type="checkbox"/>	<input type="checkbox"/>
<b>Functional Tests</b>			
Gate closes automatically and latches (alignment can be adjusted with screw-on toe board or railing).	<input type="checkbox"/>	<input type="checkbox"/>	<input type="checkbox"/>
Platform Controls – Check all switches and push buttons for proper operation:			
Emergency Stop (stops all movement)	<input type="checkbox"/>	<input type="checkbox"/>	<input type="checkbox"/>
Up/Down Controls (Elevates, Lowers, Enable button must be pressed)	<input type="checkbox"/>	<input type="checkbox"/>	<input type="checkbox"/>
Base Controls – Check all switches and push buttons for proper operation:			
Emergency Stop (stops all movement)	<input type="checkbox"/>	<input type="checkbox"/>	<input type="checkbox"/>
Key Switch (Selects Platform Control, Ground Control, or Off)	<input type="checkbox"/>	<input type="checkbox"/>	<input type="checkbox"/>
Alarm (Not damaged, sounds for descent)	<input type="checkbox"/>	<input type="checkbox"/>	<input type="checkbox"/>
Up/Down Rocker Switch (Elevates, Lowers)	<input type="checkbox"/>	<input type="checkbox"/>	<input type="checkbox"/>
Wheels: Front and rear wheels rotate freely.	<input type="checkbox"/>	<input type="checkbox"/>	<input type="checkbox"/>
Brakes engage and hold when platform is elevated.	<input type="checkbox"/>	<input type="checkbox"/>	<input type="checkbox"/>

Date: \_\_\_\_\_ Inspected By: \_\_\_\_\_





# ***Hy-Brid Lifts*** ***by Custom Equipment***

---

Push-Around Aerial Work Platform  
Operations & Safety Manual  
HB-P3.6



---

© 2014 Custom Equipment, Inc.  
2647 Highway 175  
Richfield, WI 53076  
U.S.A.  
Tel. +1-262-644-1300  
Fax: +1-262-644-1320  
[www.hybridlifts.com](http://www.hybridlifts.com)  
[service@customequipmentlifts.com](mailto:service@customequipmentlifts.com)

"Hy-Brid Lifts" is a trademark of Custom Equipment, Inc.

Revision Date: July 2014  
Printed in the U.S.A.