

HY-BRID LIFTS™

BY CUSTOM EQUIPMENT INC

OPERATION & SAFETY MANUAL
PUSH-AROUND AERIAL WORK PLATFORM

SUPO-647
REV D



HB-P4.5

HB-P5.0

SERIES 1

The purpose of this Operations and Safety manual is to provide users with the instructions and operating procedures essential to properly and safely operate the Custom Equipment Hy-Brid Lift for its intended purpose, and to position personnel and their necessary tools and materials.



THE OPERATION AND SAFETY MANUAL MUST BE READ AND UNDERSTOOD PRIOR TO OPERATING THE MACHINE.

- The user/operator should not accept operating responsibility until the manual has been read and understood as well as having operated the lift under supervision of an experienced and qualified operator.
- Because the manufacturer has no direct control over machine application and operation, proper safety practices are the responsibility of the user and all operating personnel.



ANY MODIFICATION ON THIS MACHINE WITHOUT THE EXPRESS WRITTEN CONSENT OF THE MANUFACTURER IS PROHIBITED.

Fall protection notice: The guardrail system around the perimeter of the platform is **the fall protection system** for push-around elevating work platforms per the EN 280:2001 Standard. It is **prohibited** to use an Aerial Work Platform manufactured by Custom Equipment, Inc. With any portion—or all—of the guardrails removed. Lanyard anchorage points on this type of equipment are not required to conform to the applicable standard. However, if anchorage points for lanyard attachments are required by site authorities or other regulations, the anchorage points on all equipment manufactured by Custom Equipment, Inc. Are recommended to be used for **work positioning restraints** of personnel only. Lanyard lengths are to be determined by operator/owner to restrict the operator to the confines within the guardrail system.

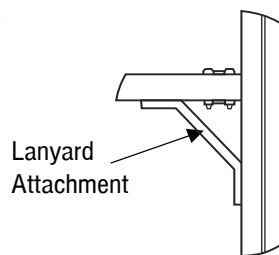

USE OF FALL ARREST SYSTEMS ATTACHED TO ANCHORAGE POINTS ON EQUIPMENT MAY CAUSE MACHINE TO TIP, RESULTING IN SERIOUS INJURY OR DEATH.

CONTENTS

SECTION 1 | PRODUCT DESCRIPTION6

1.1 General	6
1.2 Machine Specifications	7

SECTION 2 | SAFETY.....8

2.1 Safety Symbols	8
2.2 General Rules and Precautions	8
2.3 Safety Features.....	9
2.4 Safety Controls.....	9
2.5 Maintenance Lock	10
2.6 Safety Guidelines.....	11

SECTION 3 | DECALS.....12

SECTION 4 | TRANSPORT, HANDLING & STORAGE.....13

4.1 Preliminary Unpacking Instructions and Dealer Inspection	13
4.2 Storage.....	13
4.3 Transportation.....	13
4.4 Lifting and Tie-Down Points.....	13

SECTION 5 | OPERATION15

5.1 Pre-start Inspection	15
5.2 Controls	15
5.3 Startup/Shut Down	16
5.4 Elevating and Lowering	17

SECTION 6 | DAILY MAINTENANCE.....18

6.1 Charging the Battery1.....	18
6.2 Pre-start Inspection Checklist.....	20

INDEX OF FIGURES

Figure 1: Emergency Lowering Valve.....	10
Figure 2: Maintenance Lock Pin Use.....	11
Figure 3: Maintenance Lock Pin Storage	11
Figure 4: Decal Locations	13
Figure 5: Tie-Down Points	15
Figure 6: Rear Brakes.....	15
Figure 7: Base Controls.....	16
Figure 8: Platform Controls	16
Figure 9: Master Power Switch.....	17
Figure 10: Rear Brakes And Bubble Level.....	17
Figure 11: Battery Charger Led Display	20

Revision Log

REV A: Initial Release.....	February 2014
REV B:	June 2014
REV D:	December 2015

SECTION 1 | PRODUCT DESCRIPTION

1.1 | General

Custom Equipment's Hy-Brid Scissor Lift is an aerial work platform designed to be safe and reliable. The purpose of the machine is to elevate personnel, along with their necessary tools and materials. The machine is intended for indoor use (no wind load). Manufacturer approval is required for any use other than the intended use.

1.2 | EC Declaration of Conformity

We hereby declare that the above mentioned machine has been assessed, tested and approved in accordance with the requirements of the Machinery Directive 2006/42/EEC using the document EC Community Legislation on Machinery and taking guidance from EN280:2001 + A2:2009.

An EC type-examination was tested internally by the manufacturer, in accordance with EN280:2001+A2:2009 and 2006/42/EEC Annex VIII, as listed in Article 12 and Annex IV, item 17 of directive 2006/42/EEC, which excludes devices with a platform height of less than three meters.

Model Numbers: HB-P4.5, Series I & HB-P5.0, Series I
Machine Type: Mobile Elevating Work Platform
Applicable Harmonised Standard: EN280:2001+A2:2009

Manufacturer:
Custom Equipment, Inc.
2647 Hwy 175
Richfield, WI 53076
USA
Phone: +1-262-644-1300
Fax: +1-262-644-1320
www.hybridlifts.com

1.3 | Machine Specifications**HB-P4.5**

Working Height (maximum)	14 ft	4.5 m
Platform Height (maximum)	8 ft	2.5 m
Stowed Height	68.6 in	1.74 m
Ground Clearance	1.6 in	0.04 m
Overall Width	27.6 in	0.70 m
Overall Length	43 in	1.09 m
Platform	22.5 in x 36.9 in	0.56 m x 0.94 m
Guard Rail Height	43 in	1.1 m
Toe Board Height	6 in	0.15 m
Platform Entrance	25.3 in	0.64 m
Step Height	12.6 in	0.32 m
Wheel Base	35.1 in	0.89 m
Wheel Track	25.1 in	0.64 m
Turning Radius (Inside)	Zero	Zero
Tire Size (Solid, Non-Marking) - Front	8 in	20.3 cm
Tire Size (Solid, Non-Marking) - Rear	8 in	20.3 cm

Rated Load

Lift Capacity (evenly distributed)	550 lb / 1 Person	249.5 kg / 1 Person
Horizontal/Manual Force	45 lb	200 N

Floor Loading

Machine Weight (Unloaded) (Approx.)	773 lb	351 kg
Minimum Wheel Load – Contact Pressure	205.3 psi	1415 kPa
Maximum Wheel Load – Contact Pressure	351.4 psi	2422 kPa
Minimum Machine Loading – Floor Pressure	115.1 psf	5.51 kPa
Maximum Machine Loading – Floor Pressure	197.0 psf	9.43 kPa

Environmental limitations

Wind	No windy conditions / Indoor use only	
Rated Slope	Level Surface	
Temperature	-4° F - 104° F	-20° C - 40° C
Vibration	8.2 ft/s ² max	2.5 m/s ² max
Sound	86 dB Normal Use 100 dB Alarms	86 dB Normal Use 100 dB Alarms
Lift/Lower Speed	16/16 sec	16/16 sec
Hydraulic Pressure (max)	1300 psi	8963 kPa
Hydraulic Fluid Capacity	3 quarts	2.84 L
Power System – Voltage	12V DC	12V DC
Batteries – Deep Cycle Marine (Options)	12V, Group 24 AGM OR 12V, Group 27	12V, Group 24 AGM OR 12V, Group 27

SECTION 1 | PRODUCT DESCRIPTION

HB-P5.0

Working Height (maximum)	16.4 ft	4.95 m
Platform Height (maximum)	9.6 ft	2.95 m
Stowed Height	71.1 in	1.81 m
Ground Clearance	1.6 in	0.04 m
Overall Width	27.6 in	0.70 m
Overall Length	43 in	1.09 m
Platform	22 in x 37 in	0.56 m x 0.94 m
Guard Rail Height	43 in	1.1 m
Toe Board Height	6 in	0.15 m
Platform Entrance	27.8 in	0.71 m
Step Height	12.58 in	0.3 m
Wheel Base	35.1 in	0.89 m
Wheel Track	25.1 in	0.64 m
Turning Radius (Inside)	Zero	Zero
Tire Size (Solid, Non-Marking) - Front	8 in	20.3 cm
Tire Size (Solid, Non-Marking) - Rear	8 in	20.3 cm

Rated Load

Lift Capacity (evenly distributed)	550 lb / 1 Person	249.5 kg / 1 Person
Horizontal/Manual Force	45 lb	200 N

Floor Loading

Machine Weight (Unloaded) (Approx.)	870.5 lb	395 kg
Minimum Wheel Load – Contact Pressure	250.3 psi	1726 kPa
Maximum Wheel Load – Contact Pressure	408.5 psi	2816 kPa
Minimum Machine Loading – Floor Pressure	129.6 psf	6.21 kPa
Maximum Machine Loading – Floor Pressure	211.5 psf	10.13 kPa

Environmental limitations

Wind	No windy conditions / Indoor use only	
Rated Slope	Level Surface	
Temperature	-4° F - 104° F	-20° C - 40° C
Vibration	8.2 ft/s ² max	2.5 m/s ² max
Sound	86 dB Normal Use 100 dB Alarms	86 dB Normal Use 100 dB Alarms
Lift/Lower Speed	16/14 sec	16/14 sec
Hydraulic Pressure (max)	1500 psi	10 342 kPa
Hydraulic Fluid Capacity	3 quarts	2.84 L
Power System – Voltage	12 V DC	12 V DC
Batteries – Deep Cycle Marine (Options)	12V, Group 24 AGM OR 12V, Group 27	12V, Group 24 AGM OR 12V, Group 27

SECTION 2 | SAFETY

2.1 | Safety Symbols

Warnings and instructions that have a direct impact on safety are identified with the following signals:



**FAILURE TO FOLLOW THIS WARNING WILL
CAUSE DEATH OR PERSONAL INJURY.**

“DANGER” indicates an imminently hazardous situation, which, if not avoided, will result in death or serious injury.



**FAILURE TO FOLLOW THIS WARNING MAY
CAUSE DEATH OR PERSONAL INJURY.**

“WARNING” indicates a potentially hazardous situation, which, if not avoided, could result in death or serious injury



**FAILURE TO FOLLOW THIS WARNING MAY
CAUSE INJURY OR DAMAGE EQUIPMENT**

“CAUTION” indicates a potentially hazardous situation which, if not avoided, could result in minor or moderate injury or damage to equipment

2.2 | General Rules and Precautions

Custom Equipment, Inc. designed the Hy-Brid Lift push-around scissor lift to be safe and reliable. It is intended for elevating personnel, along with their necessary tools and materials to overhead work locations. Vibration does not create significant hazards on this machine.

An operator of any type of work platform is subject to certain hazards that cannot be protected by mechanical means. It is therefore essential that operators be competent, careful, physically and mentally fit, and thoroughly trained in safe operation of this machine. Although Custom Equipment, Inc. conforms to specified EN: 280 requirements, it is the responsibility of the owner to instruct operators with the safety requirements made not only by Custom Equipment, Inc., but by the various safety boards in your area, as well as additional requirements set forth by EN: 280 If you come across a situation that you think might be unsafe, stop the platform and request further information from qualified sources before proceeding.



NEVER REACH BETWEEN SCISSORS LINKS OR PROP UP PLATFORM.



WHEELS EXTENDING BEYOND THE SIDES OF THE BASE MAY OCCUR IN TIGHT TURNING SITUATIONS.

2.3 | Safety Features

- Puncture-proof wheels.
- Guardrails—43.83 in height with 4 in kick plates
- Non-slip deck.
- Entrance gate.
- Automatic brake when elevated
- Free descent protection. A pressure compensated flow control valve is installed in the hydraulic circuit to prevent the platform from descending in case of a ruptured hydraulic hose. The platform is hydraulically locked with a check valve and has controlled descent when valve activates.
- Decals. Danger, Caution, and Warning decals are displayed at various locations on this unit
- Key Switch Security. A key switch is required to prevent unauthorized use.

2.4 | Safety Controls

Descent — Manual Override

For manually lowering the scissors, a manual valve is provided. To lower the scissors, pull the cable located near the front of the machine.

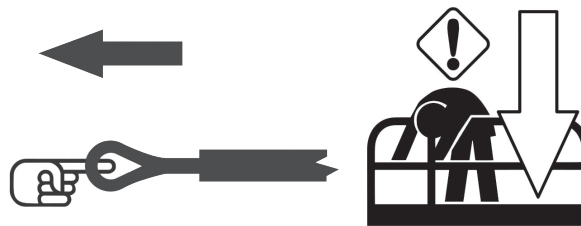
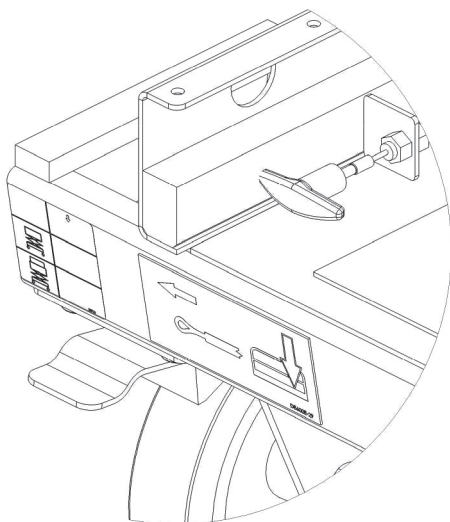

DE600E-29



If platform should fail to lower, do not attempt to climb down the beam assembly. Serious injury may result. Have an experienced operator use the emergency lowering procedure to safely lower the platform.

Emergency Stop

This lift is equipped with two emergency stop switches, one at the platform control and one at the base control, that when activated, will render the unit inoperable until reset. To reset, pull the button out.



Pushing the emergency stop button will stop movement immediately. This may cause unexpected platform movement as the machine comes to a sudden stop. Brace yourself and secure objects on the platform during operation of the machine.

2.5 | Maintenance Lock

The maintenance lock must be placed into position whenever the machine is being serviced in a partially raised position. Serious injury and/or death could result if maintenance lock is not used properly.

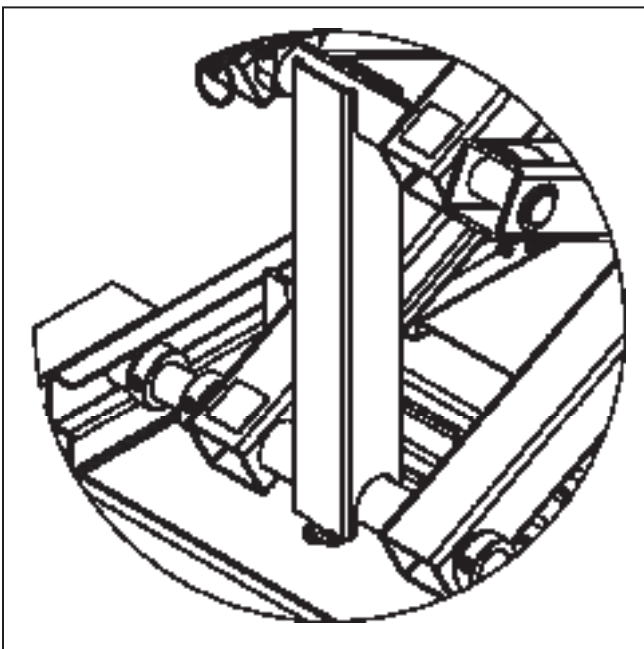

Figure 2: Maintenance Lock Use

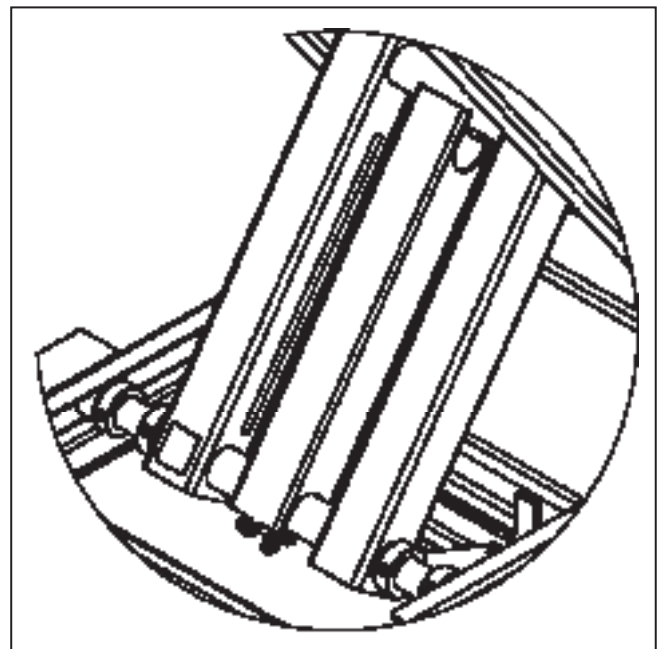

Figure 3: Maintenance Lock Storage

2.6 | Safety Guidelines

- Only qualified operators may operate this unit.
- All operators must read and understand the Operation and Safety Manual. They must understand all decals and warning labels on unit.
- Do not work on platform if your physical condition is such that you feel dizzy or unsteady in any way.
- Do not neglect/misuse machine. Report any misuse of equipment to proper personnel.
- Prevent unauthorized use; when unit is not in use, remove key.
- It is recommended all personnel on unit wear approved personal protective equipment (PPE), i.e. head gear.
- Use machine only for purposes for which it was intended.
- Lift should never be used as a crane.
- Do not exceed the load capabilities of the platform.
- Distribute load evenly over platform floor area.
- Never use unit as electrical grounds for arc welding.
- Do not override any hydraulic, mechanical, or electrical safety devices.
- Check job site for unsafe working conditions.
- Watch out for others. Keep others clear of operating platform. Never allow others to pass under a raised platform or position the platform over someone.
- Avoid contact with fixed (buildings, etc.) or moving (vehicles, cranes, etc.) objects. Check work area for overhead obstructions or possible hazards.
- Follow any applicable national traffic regulations.
- Use indoors only. Lift is not designed for windy conditions or electrical storms.
- Unit must be on hard level surface before elevating. Do not operate on incline or uneven surface.
- You must maintain a clearance between any part of the machine, or its load, and any electrical line or apparatus. Follow local power line clearance regulations.
- You must maintain a clearance between any part of the machine, or its load, and any electrical line or apparatus. Follow local power line clearance regulations.



- Do not operate machine near power lines. The platform and enclosures are not insulated. Equipment is only as safe as the operator.
- Do not use ladders or scaffolding on the platform to obtain greater height.
- Do not enter or exit platform while machine is in motion.
- Never mount or dismount a raised platform.
- Make sure entry gate is secured before operating machine from the platform.
- Never belt or tie off to an adjacent structure.
- Secure tools and materials.
- Personnel must maintain a firm footing on the platform floor and work only within the platform area.
- Before operation, ensure that the machine is properly serviced.
- Do not use machine if it is not working properly.
- Make sure platform rails and pins are secured.
- Operator shall use the maintenance lock when performing all types of maintenance procedures.
- Do not smoke while charging the battery.

SECTION 3 | DECALS

Figure 4: Decal Locations

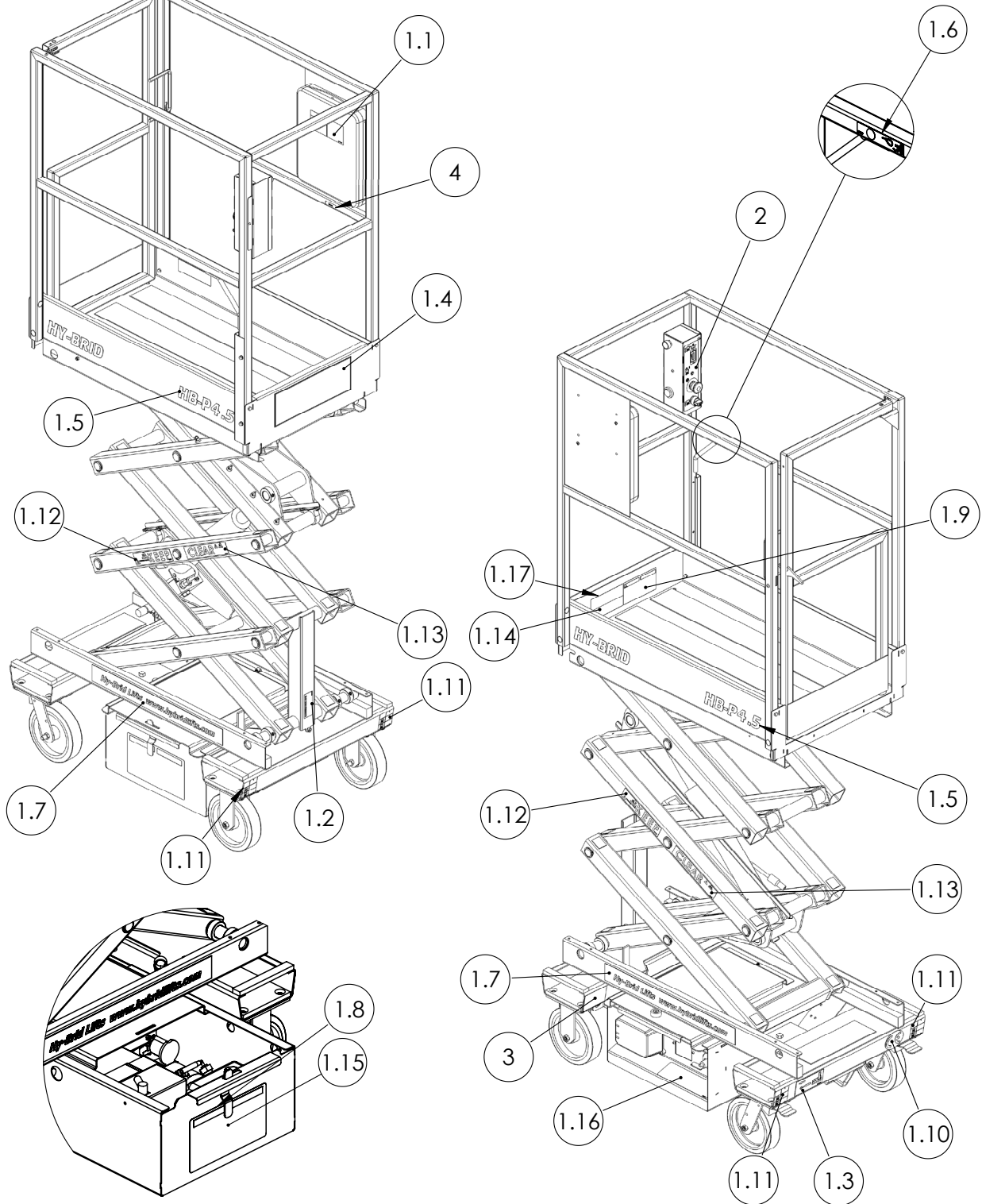

Item #	Part #	Decal Meaning or Designation	QTY.
1	144-21-007-51	Decals, HB-P4.5	1
1.1	DE600E-10	DECAL, MANUAL BOX	1
1.2	DE600E-14	DECAL, ML	1
1.3	DE751	DECAL,E-DOWN	1
1.4	DE601	DECAL,LOGO	1
1.5	DE603-7 OR DE603-8	DECAL, MODEL #HB-P4.5 OR DECAL, MODEL #HB-P5.0	2
1.6	DE746	DECAL,LANYARD ATTACHMENT	1
1.7	DE652	DECAL,WEBSITE	2
1.8	DE679	DECAL,HYDR FLUID	1
1.9	DE706	DECAL,UPR	1
1.10	DE718	DECAL,CE MARK	1
1.11	DE723 OR DE729	DECAL,WHEEL LOAD HB-P4.5 OR DECAL,WHEEL LOAD HB-P5.0	4
1.12	DE727	DECAL, KEEP	2
1.13	DE728	DECAL,CLEAR	2
1.14	DE730	DECAL,OL ALARM	1
1.15	DE739	DECAL,LWR	1
1.16	DE740	DECAL,LWR PWR	
1.17	DE742	DECAL,CAPACITY,550#,1P,I,WO/SO	2
2	DE738	DECAL,CTL UPR	1
3	NA	SERIAL NUMBER PLATE	1
4	NA	SERIAL NUMBER REFERENCE	1

SECTION 4 | TRANSPORT, HANDLING & STORAGE

4.1 | Preliminary Unpacking Instructions and Dealer Inspection

Maintenance locks must be engaged prior to inspecting or servicing the unit when the platform is elevated. Inspect machine for any possible damage during shipment; perform a pre-delivery inspection. See checklist in the Maintenance Manual. Reset emergency stop switches, if necessary.

4.2 | Storage

After periods of storage, exposure to extremes of ambient conditions-heat, cold, moisture, dust etc., inspect the machine. Refer to the Pre-Delivery/ Frequent Inspection Checklist in the Maintenance Manual.

4.3 | Transportation

Lower the work platform to the down position. Turn key switch to off position. For safety and controlled handling, it is not recommended to move the unit on a slope greater than 5°. Check entire machine for loose or unsecured items. Remove any loose items from machine. Apply manual brake lock on rear wheels.

4.4 | Lifting and Tie-Down Points

Lower the work platform to the down position. Turn key switch to off position. For safety and controlled handling, it is not recommended to move the unit on a slope greater than 5°. Check entire machine for loose or unsecured items. Remove any loose items from machine. Apply manual brake lock on rear wheels.

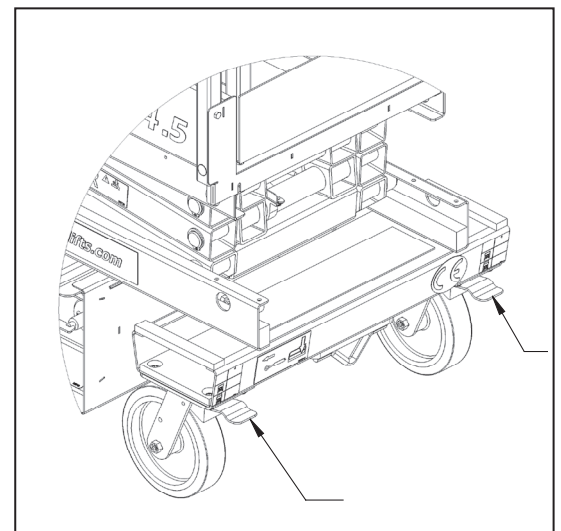

Figure 6: Rear Brakes

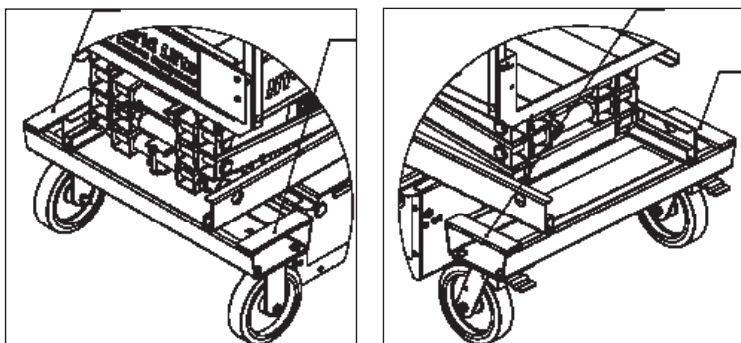

Figure 5: Tie-Down Points

SECTION 5 | OPERATION

5.1 | Pre-start Inspection

Before use each day or at the beginning of each shift, the machine shall be given a visual inspection and functional test. Repairs (if any) must be made prior to operating the machine, as it is critical to ensure safe operation of the machine. A checklist for pre-start inspection can be found in the back of this manual.

5.2 | Controls

Figure 7: Base Controls

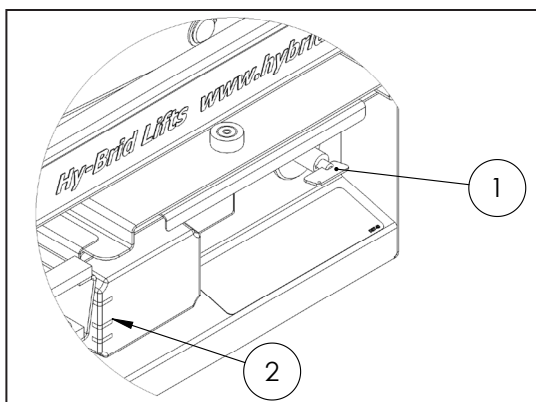

Item	Control/Indicator
1	Master Power Switch Operation described as follows
2	Battery Charger Indicator Lights

Figure 8: Platform Controls

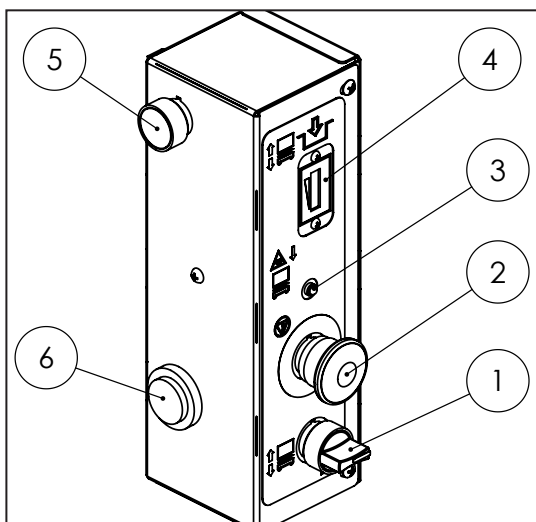

Item	Control/Indicator
1	Up/Down Rotary Switch Operation described as follows
2	Emergency Stop Operation described in Section 2.4
3	Overload Indicator Light
4	Battery Voltage Meter
5	Lift Enable Button Operation described as follows
6	Alarm Sounds for descent, overload

5.3 | Startup/Shut Down

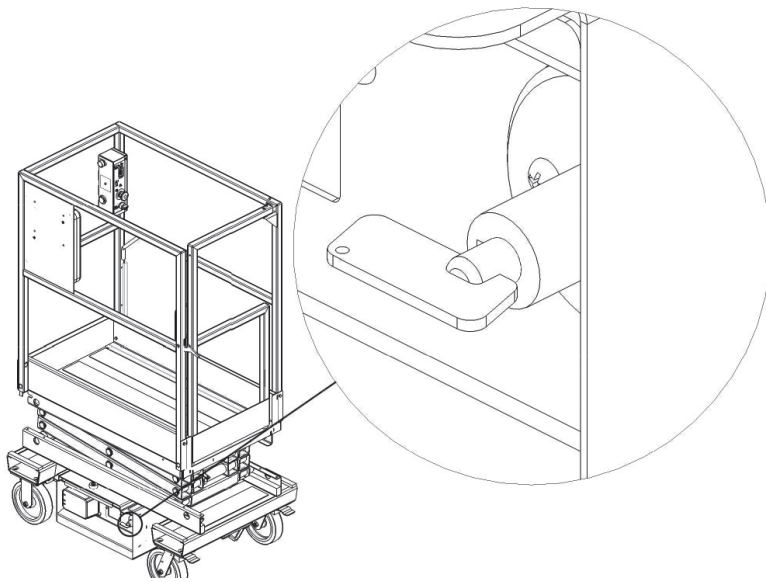

Figure 9: Master Power Switch

Check that the work area is safe. It is not recommended to maneuver the unit on a slope greater than 5°. Check that master power switch is in "ON" position. Ensure that the key in the lower control panel is in the "ON" position for the chassis or platform control. Machine must be on a hard, level, surface before operation. Check that bubble level is centered. Engage the manual brakes on the rear casters before elevating the platform.



THE OPERATOR MUST BE AWARE OF THE ENVIRONMENT. DO NOT RAISE THE PLATFORM IF THE MACHINE IS NOT ON A FIRM, LEVEL SURFACE.

Enter the work platform in the stowed position using the constant three point contact method. Follow all general rules and precautions stated in this manual. When finished with the machine, place the platform in the stowed position. Carefully exit the platform using the constant three point contact method.

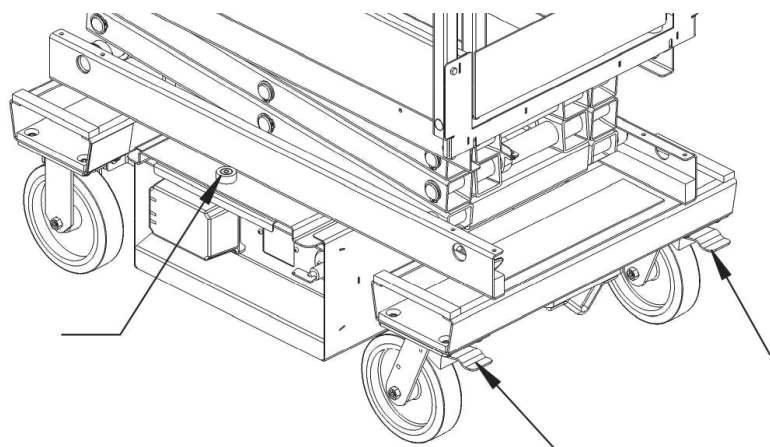

NEVER JUMP OFF PLATFORM. Park the machine on a level surface. Remove key from lower control panel to prevent unauthorized use.

Figure 10: Rear Brakes and Bubble Level

5.4 | Elevating and Lowering

Using Upper Platform Controls

Make sure the platform controls are selected with the selector switch at the base controls. To raise or lower the platform, press the Elevate/Lower Enable Button. While holding down the Enable Button, rotate and hold the Elevate/Lower switch until the platform is in the desired position.

Using Lower Base Controls

Make sure the base controls are selected with the selector switch at the base controls. Press the Enable Button at the same time as the Elevate/Lower Switch to raise or lower the platform. Pressing the top of the switch raises the platform, pressing the bottom lowers the platform.

SECTION 6 | DAILY MAINTENANCE



Failure to perform inspections and preventative maintenance at recommended intervals may result in the unit being operated with a defect that may result in injury or death of the operator. Regular inspection and conscientious maintenance is important to efficient economical operation of this machine. It will help to assure that equipment will perform satisfactorily with a minimum of service and repair. Make checks at the stated intervals or more frequently if required by local operating conditions. A Pre-Start Inspection Checklist is included in this manual.

Additional maintenance for use by trained personnel is included in a separate Maintenance Manual. Refer to the Maintenance Manual for Pre-Delivery/Frequent and Monthly Checklists and replacement part information.

6.1 | Charging the Battery

This unit is equipped with a deep cycle 12-volt battery. The care and maintenance of your battery has much to do with how well this unit functions. Battery wiring should be checked monthly.

NOTE: The surrounding temperature greatly affects the power reserve within a battery.

Example: A battery that is 100% charged at 80° F (27°C) drops to 65% at 32°F (0°C). At 0°F (-18°C), this battery will drop to 40% efficiency.



Lead-acid batteries generate explosive gases. Keep sparks and flame away from batteries. Do not smoke while charging.

Do not operate unit while charging. Shortened battery life will result.

Park the machine on a level surface.

Plug charger into AC outlet until charged.

For best battery life, leave charger plugged in until machine will be used again. The charger will maintain the battery charge.

The charger will not begin the charging cycle on severely discharged batteries.



**DO NOT OPERATE UNITE WHILE
CHARGING**



**NEVER ADD ACID TO THE
BATTERY**

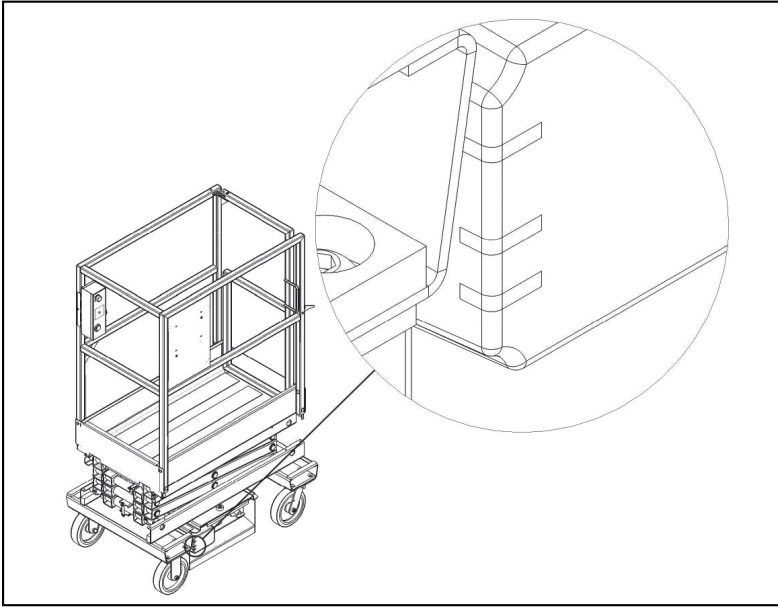

Battery solution is at its proper strength when the battery is manufactured. Use distilled water and keep fluid up to proper level. When required, water should be added to battery after charging, unless water level is below the plates.

Figure 11: Battery Charger LED Display

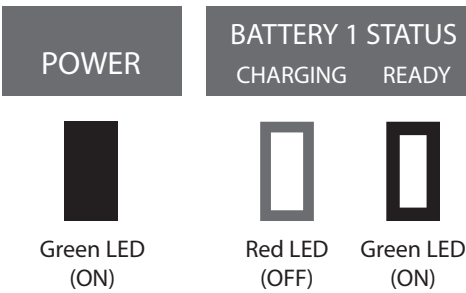

Reading the Battery Displays

This display indicates that the power is on but there is no connection to a battery. The charger must see approximately five (5) volts on a battery to deliver D/C current.

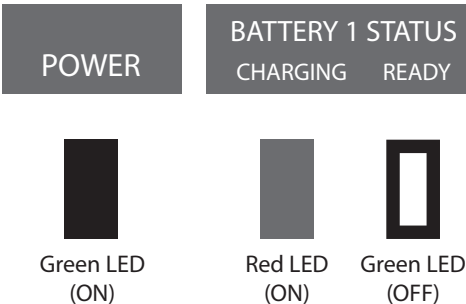

This display indicates that power is on and that both outputs are delivering D/C current to the batteries.

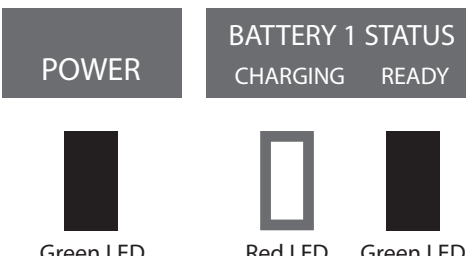

This display indicates that power is on and that the output is finished charging and is in a float maintenance model.

6.2 | Pre-start Inspection Checklist



This checklist must be used at the beginning of each shift or after every six to eight hours of use. Failure to do so could affect the safety of the operator.

MODEL NUMBER: _____ **SERIAL NUMBER:** _____

Keep inspection records up-to-date.

Record and report all discrepancies to your supervisor.

A dirty machine cannot be properly inspected.

Y – Yes/Acceptable N – No/Unacceptable R – Repaired

Description	Y	N	R
Visual Inspections			
Check that there are no damaged, dented, or bent structural members.	<input type="checkbox"/>	<input type="checkbox"/>	<input type="checkbox"/>
There are no loose or missing parts.	<input type="checkbox"/>	<input type="checkbox"/>	<input type="checkbox"/>
Check that warning and instructional labels are legible and secure. Ensure that load capacity is clearly marked.	<input type="checkbox"/>	<input type="checkbox"/>	<input type="checkbox"/>
Check the platform rails and safety gate for damage.	<input type="checkbox"/>	<input type="checkbox"/>	<input type="checkbox"/>
Platform and base controls are not missing, damaged, or disconnected.	<input type="checkbox"/>	<input type="checkbox"/>	<input type="checkbox"/>
Electrical cables and wires are not torn, frayed, or disconnected.	<input type="checkbox"/>	<input type="checkbox"/>	<input type="checkbox"/>
Hydraulic hoses are not torn or loose, and there are no leaks. Check that hoses and cables have no worn areas or chafing.	<input type="checkbox"/>	<input type="checkbox"/>	<input type="checkbox"/>
Check the tires for damage.	<input type="checkbox"/>	<input type="checkbox"/>	<input type="checkbox"/>
Check that all snap rings are secure in grooves on pivot pins.	<input type="checkbox"/>	<input type="checkbox"/>	<input type="checkbox"/>
Functional Tests			
Gate closes automatically and latches (alignment can be adjusted with screw-on toe board or railing).	<input type="checkbox"/>	<input type="checkbox"/>	<input type="checkbox"/>
Platform Controls – Check all switches and push buttons for proper operation:			
Emergency Stop (stops all movement)	<input type="checkbox"/>	<input type="checkbox"/>	<input type="checkbox"/>
Up/Down Controls (Elevates, Lowers, Enable button must be pressed)	<input type="checkbox"/>	<input type="checkbox"/>	<input type="checkbox"/>
Base Controls – Check all switches and push buttons for proper operation:			
Emergency Stop (stops all movement)	<input type="checkbox"/>	<input type="checkbox"/>	<input type="checkbox"/>
Key Switch (Selects Platform Control, Ground Control, or Off)	<input type="checkbox"/>	<input type="checkbox"/>	<input type="checkbox"/>
Alarm (Not damaged, sounds for descent)	<input type="checkbox"/>	<input type="checkbox"/>	<input type="checkbox"/>
Up/Down Rocker Switch (Elevates, Lowers)	<input type="checkbox"/>	<input type="checkbox"/>	<input type="checkbox"/>
Wheels: Front and rear wheels rotate freely.	<input type="checkbox"/>	<input type="checkbox"/>	<input type="checkbox"/>
Brakes engage and hold when platform is elevated.	<input type="checkbox"/>	<input type="checkbox"/>	<input type="checkbox"/>

DATE _____ INSPECTED BY _____

HY-BRID LIFTS™

BY CUSTOM EQUIPMENT INC

PUSH-AROUND AERIAL WORK PLATFORM
OPERATION & SAFETY MANUAL
HB-P4.5 / HB-P5.0



© 2015 Custom Equipment, Inc.
2647 Highway 175
Richfield, WI 53076
U.S.A.
Tel. +1-262-644-1300
Fax: +1-262-644-1320
www.hybridlifts.com
service@customequipmentlifts.com

"Hy-Brid Lifts" is a trademark of Custom Equipment, Inc.
These machines comply with specified EN:280 requirements
Revision Date: December 2015
Printed in the U.S.A.