

P 180

PALFINGER



Comfortable Multi-talented All-rounder for Municipal Enterprises and Energy Suppliers

Where others gave up long ago is where the P 180 really begins to show what it can do. The new access platform from the established premium class is unbeatably powerful in difficult terrain due to its maximum permissible setup inclination. An intelligent automatic stabiliser system and an array of comfort functions that are normally only found on heavy load platforms make an operator's life a whole lot easier. Commercially-minded municipal enterprises and energy suppliers appreciate the generous additional payload and the basket load of 350 kg.

The P 180 guarantees long-term value retention

P 180 Working range

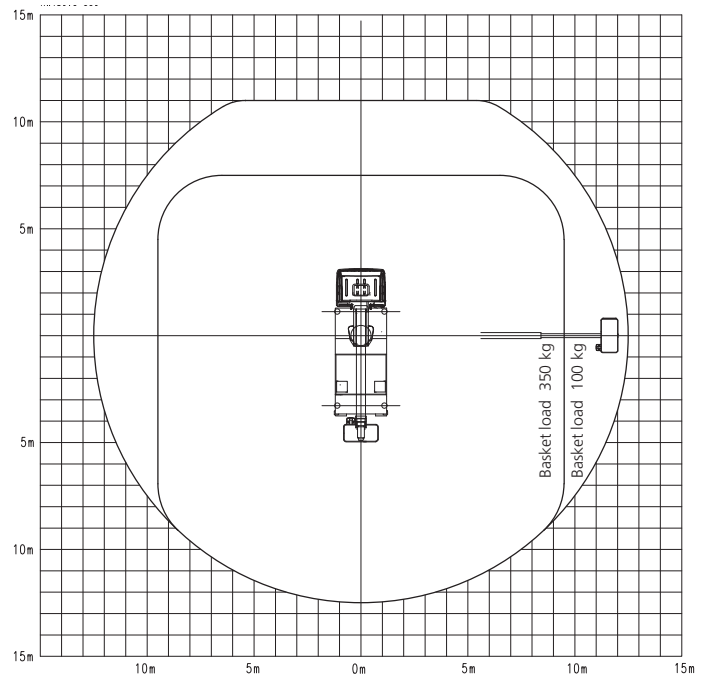
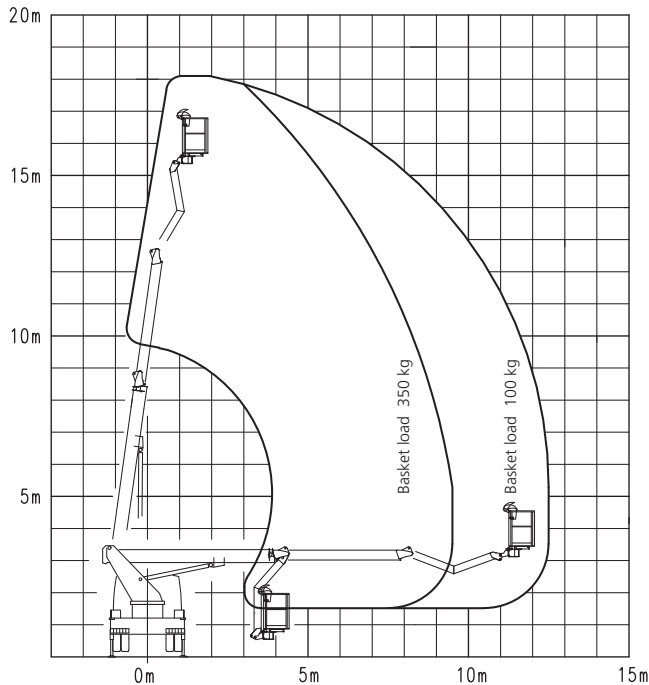

Technical Data P 180

Max. working height	18.0 m
Max. basket floor height	16.0 m
Max. horizontal outreach with aluminium cage* (with 100 kg cage load and mounted on a 7,5 t chassis)	12.5 m
Length in transport position**	ca. 7.70 m
Width in transport position**	ca. 2.50 m
Height in transport position**	ca. 3.50 m
Angle of slope**	13°
4 hydraulically extendable outriggers***	2.5 m

Max. permissible inclination	0°–5° continuous
Slewing range turn table	540°
Design	Torsion stiff sub-frame
Telescopes in the lifting boom	1
Workman basket (LxWxH)	1.60 x 0.80 x 1.10 m
Hydraulic basket pivot drive: pivoting range	+/- 80°
Max. permissible load	350 kg

*) Depending on the additional equipment ***) Depending on the chassis
***) Stabiliser width from outer edge to outer edge of stabiliser plates

