

PALFINGER

P 200 TXE SMART
MINIMUM
DIMENSIONS
MAXIMUM
PERFORMANCE

LIFETIME EXCELLENCE



TECHNICAL SPECIFICATIONS

Max. working height	19.8 m
Max. basket bottom height	17.8 m
Max. outreach	10.6 m
Angle of main boom	-21° a + 80°
Turntable rotation	370°
Basket rotation	2 x 90°
Basket load	250 kg
Size of basket	1.4 x 0.85 x 1.1 m
Height in transport position	2.87 m
Width in transport position	2.10 m
Length in transport position	7.10 m
GVW	3500 kg

OPTIONAL

Fiberglass basket
Electric pump for internal use
Working adjustable light 60 W on the basket
Insulation 1000 V
12 V electric pump
Aluminium side panels
Customised paintwork boom

WORKING DIAGRAMS

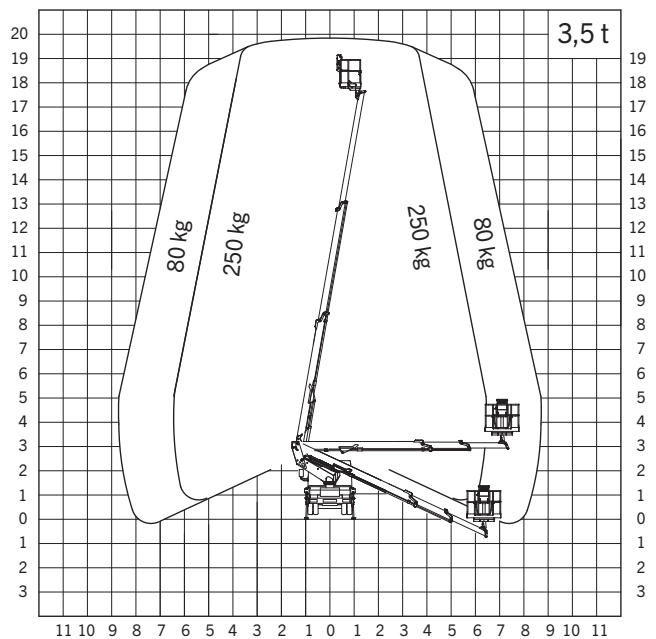
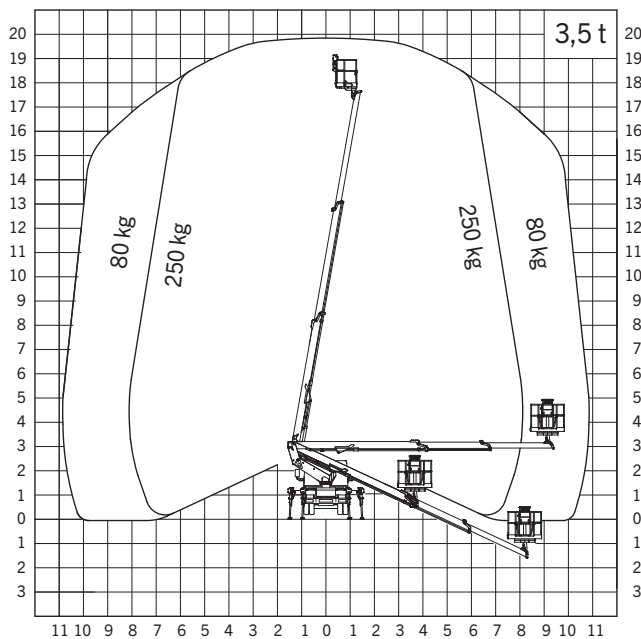

DIMENSIONS

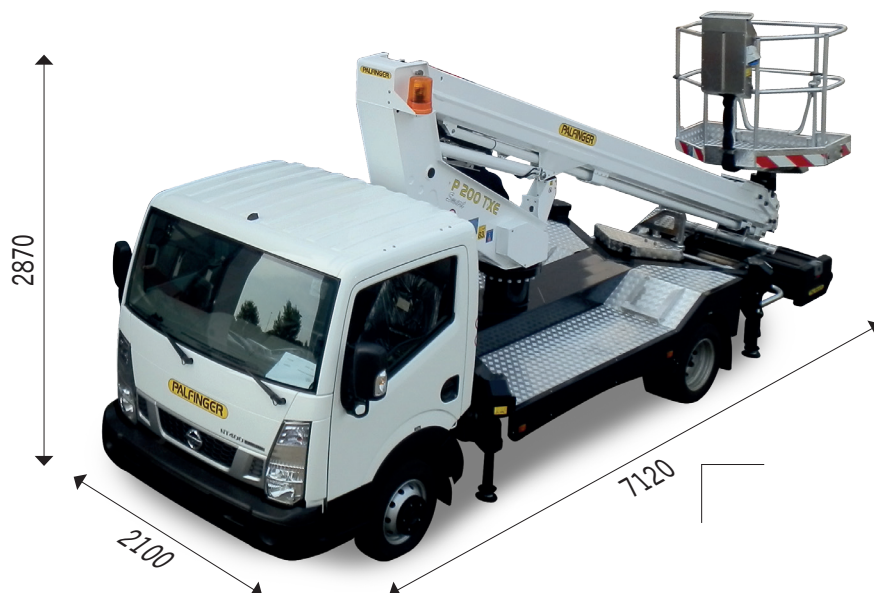

SALES DEALER