



KL12.5
Products



The most compact among wheel loaders

Compact and manoeuvrable wheel loaders for various applications with optional performance hydraulics. With an optimised power to weight ratio, low shipping weight and continuous high payload, the efficiency invoice with this model series is in favour of the end user.

- One-piece frame and all-wheel steering
- Hydraulic quick coupler system and parallel-controlled loading system
- Spacious cab with perfect circumferential visibility
- Efficient drive and low operating costs
- Versatility through third control circuit and power flow



Technical specifications

Operating data

Bucket capacity (standard bucket)	0,35 m ³
Operating weight (CANOPY)	1.620 kg

Engine / Motor

Engine / Motor manufacturer	Yanmar
Engine performance	23 kW

Power transmission

Travel speed	20 km/h
Standard tires	28x9.00-15

Steering and operating hydraulics

Flow rate (pump)	20 l/min
Pressure (maximum)	240 bar
Flow rate (optional)	60 l/min

Kinematics

Tipping load (with bucket)	1.250 kg
Payload (S=1.25)	750 kg

Additional technical data is available in the detailed brochure in the informational material section



Dimensions

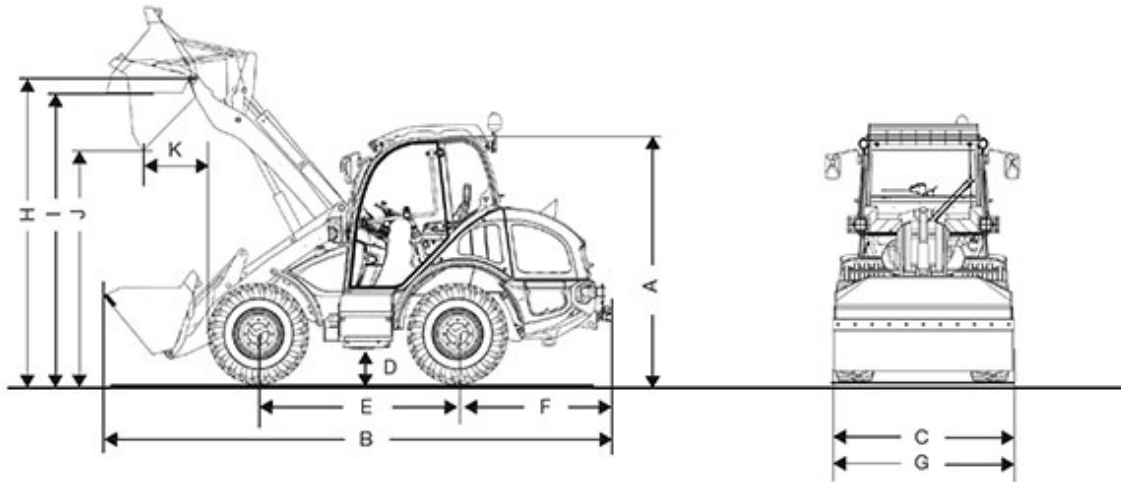

A	Height	1.990 mm
B	Length	4.080 mm
C	Width	1.200 mm
D	Ground clearance	230 mm
E	Wheelbase	1.525 mm
	Center of front axle to tip of teeth	1.360 mm
F	Center of rear axle to end of vehicle	1.195 mm
G	Bucket width	1.200 mm
H	Bucket pivot point	2.790 mm
I	Overhead loading height	2.680 mm



J	Dumping height	2.250 mm
K	Dump reach	165 mm
	Stack height	2.680 mm
	Turning radius (over tyres)	1.950 mm

All information was determined with the following tires: 287x79.007-715

Please note

that product availability can vary from country to country. It is possible that information / products may not be available in your country. More detailed information on engine power can be found in the operator's manual; the stated power may vary due to specific operating conditions.

Subject to alterations and errors excepted. Applicable also to illustrations.

Copyright © 2017 Kramer-Werke GmbH.