



KL19.5
Products



The compact genius among wheel loaders

Compact and manoeuvrable wheel loader for various applications with optional performance hydraulics. With an optimised power to weight ratio, low shipping weight and continuous high payload, the efficiency invoice with this model series is in favour of the end user.

- One-piece frame and all-wheel steering
- Hydraulic quick coupler system and parallel-controlled loading system
- Spacious cab with perfect circumferential visibility
- Efficient drive and low operating costs
- Versatility through third control circuit and power flow



Technical specifications

Operating data

Bucket capacity (standard bucket)	0,55 m ³
Operating weight	3.450 kg

Engine / Motor

Engine / Motor manufacturer	Yanmar
Engine performance	35 kW

Power transmission

Travel speed (standard)	20 km/h
Travel speed (optional)	30 km/h
Standard tires	12.0-18

Steering and operating hydraulics

Flow rate (pump)	56 l/min
Pressure (maximum)	235 bar
Flow rate (optional)	90 l/min

Kinematics

Tipping load (with bucket)	1.980 kg
Payload (with pallet fork S=1.25)	1.600 kg

Weitere technische Daten finden Sie in der ausführlichen Broschüre im Bereich Infomaterial



Dimensions

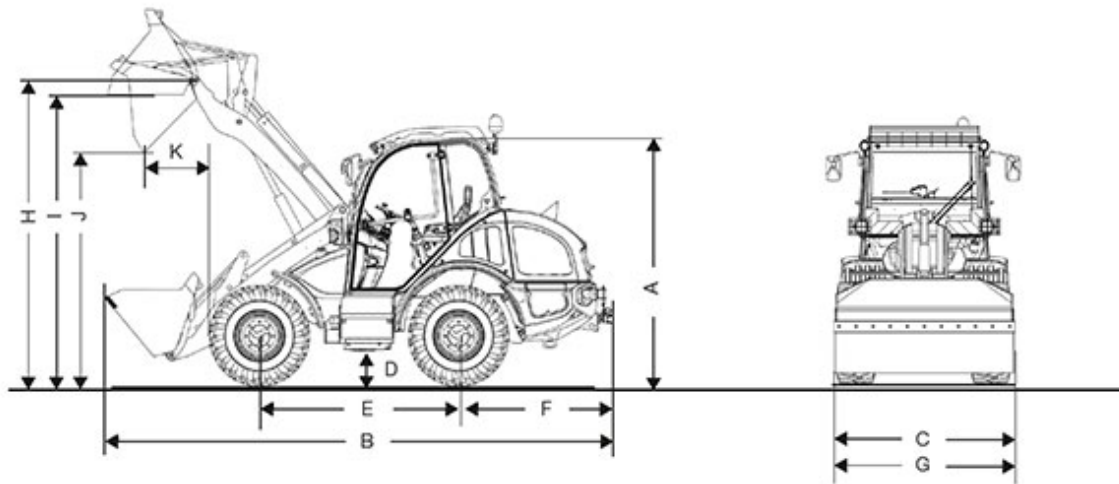

A	Height	2.380 mm
B	Length	4.950 mm
C	Width	1.566 mm
D	Ground clearance	270 mm
E	Wheelbase	1.850 mm
	Center of front axle to tip of teeth	1.780 mm
F	Center of rear axle to end of vehicle	1.320 mm
G	Bucket width	1.650 mm
H	Bucket pivot point	3.040 mm
I	Overhead loading height	2.890 mm



J	Dumping height	2.320 mm
K	Dump reach	300 mm
	Stack height	2.820 mm
	Turning radius (over tyres)	2.700 mm

All information was determined with the following tires: 10.5 – 18

Please note

that product availability can vary from country to country. It is possible that information / products may not be available in your country. More detailed information on engine power can be found in the operator's manual; the stated power may vary due to specific operating conditions.

Subject to alterations and errors excepted. Applicable also to illustrations.

Copyright © 2017 Kramer-Werke GmbH.