



## KL31.5 Products



### The down-to-earth performer

The new 5 Series models feature simple operation, compact design and manoeuvrability. Even in the economy class, the rigid frame and the all-wheel steering provide you with all the Kramer benefits such as constant payload, stability and manoeuvrability.

- Undivided frame and all-wheel steering for constant payload, stability and manoeuvrability
- The 5085T features a hydraulic quick-hitch system and a loading system as well as Z kinematics.
- Spacious newly developed cab with superb all-round visibility
- Efficient high-pressure drive system for low operating costs and high thrusting force
- Diverse options provide versatility



## Technical specifications

### Operating data

Bucket capacity (standard bucket)	0,75 m <sup>3</sup>
Operating weight	4.100 kg

### Engine / Motor

Engine / Motor manufacturer	Yanmar
Engine performance	35 kW

### Power transmission

Travel speed	20 km/h
Standard tires	12.5-18

### Steering and operating hydraulics

Flow rate (pump)	52 l/min
Pressure (maximum)	210 bar

### Kinematics

Tipping load (with standard bucket)	3.150 kg
Payload (S = 1.25)	1.900 kg

Weitere technische Daten finden Sie in der ausführlichen Broschüre im Bereich Infomaterial



## Dimensions

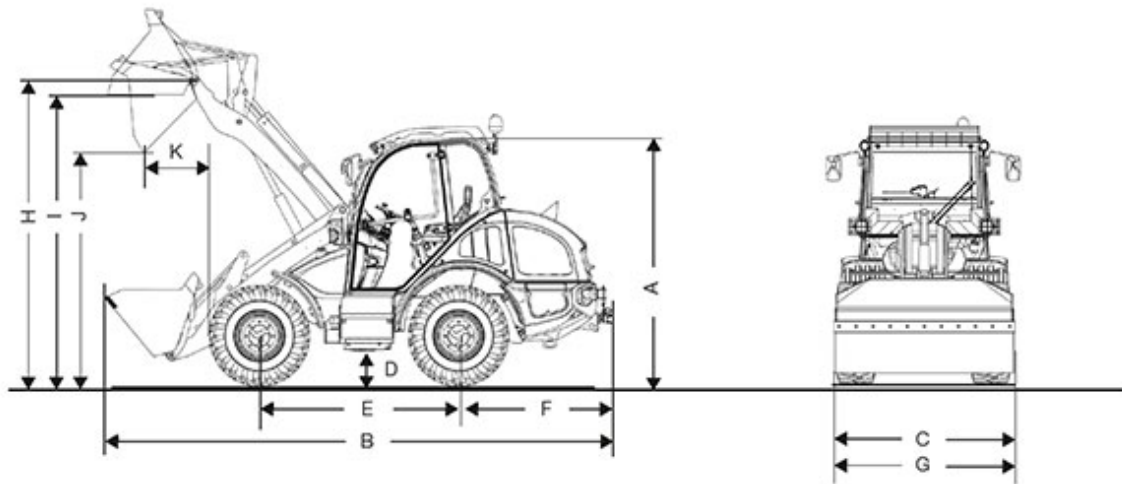

A	Height	2.450 mm
B	Length	5.080 mm
C	Width	1.720 mm
D	Ground clearance	300 mm
E	Wheelbase	2.020 mm
	Center of front axle to tip of teeth	1.570 mm
F	Center of rear axle to end of vehicle	1.490 mm
G	Bucket width	1.750 mm
H	Bucket pivot point	3.065 mm
I	Overhead loading height	2.915 mm



J	Dumping height	2.400 mm
K	Dump reach	650 mm
	Stack height	2.800 mm
	Turning radius Tyres	2.840 mm

Alle Angaben wurden mit folgender Bereifung ermittelt: 28 x 9.00 – 15

**Please note**

that product availability can vary from country to country. It is possible that information / products may not be available in your country. More detailed information on engine power can be found in the operator's manual; the stated power may vary due to specific operating conditions.

Subject to alterations and errors excepted. Applicable also to illustrations.

Copyright © 2017 Kramer-Werke GmbH.