



KL37.5
Products



The down-to-earth performer

The new 5 Series models feature simple operation, compact design and manoeuvrability. Even in the economy class, the rigid frame and the all-wheel steering provide you with all the Kramer benefits such as constant payload, stability and manoeuvrability.

- Undivided frame and all-wheel steering for constant payload, stability and manoeuvrability
- The 5085T features a hydraulic quick-hitch system and a loading system as well as Z kinematics.
- Spacious newly developed cab with superb all-round visibility
- Efficient high-pressure drive system for low operating costs and high thrusting force
- Diverse options provide versatility



Technical specifications

Operating data

Bucket capacity (standard bucket)	0,95 m ³
Operating weight	4.800 kg

Engine / Motor

Engine / Motor manufacturer	Kohler
Engine performance	55,4 kW

Power transmission

Travel speed	20 km/h
Travel speed (optional)	30 km/h
Standard tires	12.5-20

Steering and operating hydraulics

Flow rate (pump)	70 l/min
Pressure (maximum)	240 bar

Kinematics

Tipping load (with standard bucket)	3.700 kg
Payload (S = 1.25)	2.300 kg

Additional technical data is available in the detailed brochure within the informational material section



Dimensions

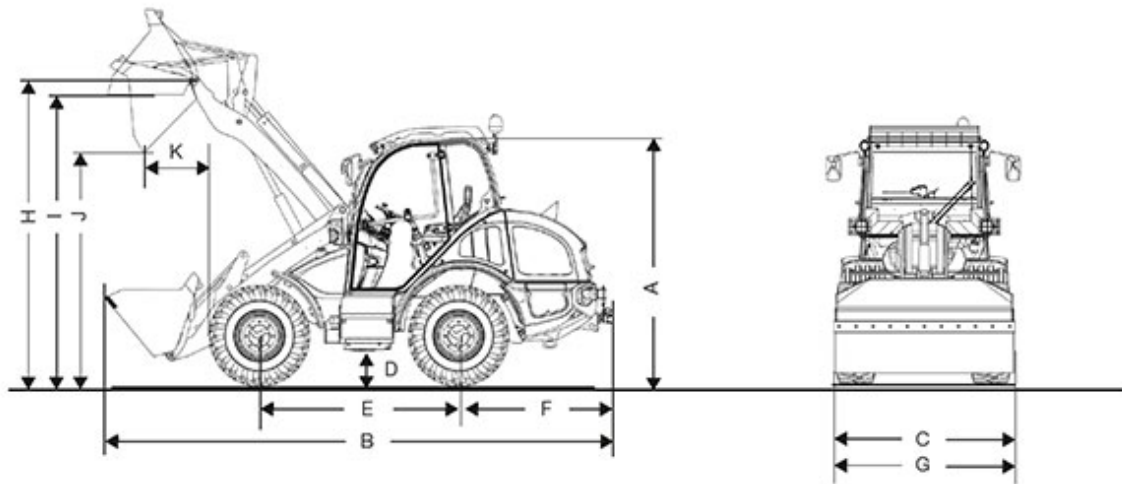

A	Height	2.480 mm
B	Length	5.410 mm
C	Width	1.720 mm
D	Ground clearance	330 mm
E	Wheelbase	2.020 mm
	Center of front axle to tip of teeth	1.900 mm
F	Center of rear axle to end of vehicle	1.490 mm
G	Bucket width	1.950 mm
H	Bucket pivot point	3.290 mm
I	Overhead loading height	3.090 mm



J	Dumping height	2.580 mm
K	Dump reach	650 mm
	Stack height	3.040 mm
	Turning radius (above tyres)	2.840 mm

Alle Angaben wurden mit folgender Bereifung ermittelt: 28 x 9.00 – 15

Please note

that product availability can vary from country to country. It is possible that information / products may not be available in your country. More detailed information on engine power can be found in the operator's manual; the stated power may vary due to specific operating conditions.

Subject to alterations and errors excepted. Applicable also to illustrations.

Copyright © 2017 Kramer-Werke GmbH.