



**KL37.8**  
Products



The premium class among wheel loaders

The wheel loaders of the premium class by Kramer set standards in terms of technology, performance and comfort. Other plus points are its versatility in use, its optimal weight ratio and its exceptional performance values.

- One-piece frame and all-wheel steering
- Hydraulic quick coupler system and parallel-controlled loading system
- Particularly spacious panoramic cab with the highest level of operator comfort
- Efficient drive and low operating costs
- Variety of options for a large range of uses



## Technical specifications

### Operating data

Bucket capacity (standard bucket)	0,95 m <sup>3</sup>
Operating weight	4.990 kg

### Engine / Motor

Engine / Motor manufacturer	Deutz
Engine performance	55 kW

### Power transmission

Travel speed (standard)	20 km/h
Travel speed (optional)	40 km/h
Standard tires	405/70R18
Differential lock	Self-locking differential

### Steering and operating hydraulics

Flow rate (pump)	70 l/min
Pressure (maximum)	240 bar
Flow rate (optional)	115 l/min

### Kinematics

Tipping load (with bucket)	3.750 kg
Payload (with pallet fork S=1.25)	2.300 kg

Weitere technische Daten finden Sie in der ausführlichen Broschüre im Bereich Infomaterial



## Dimensions

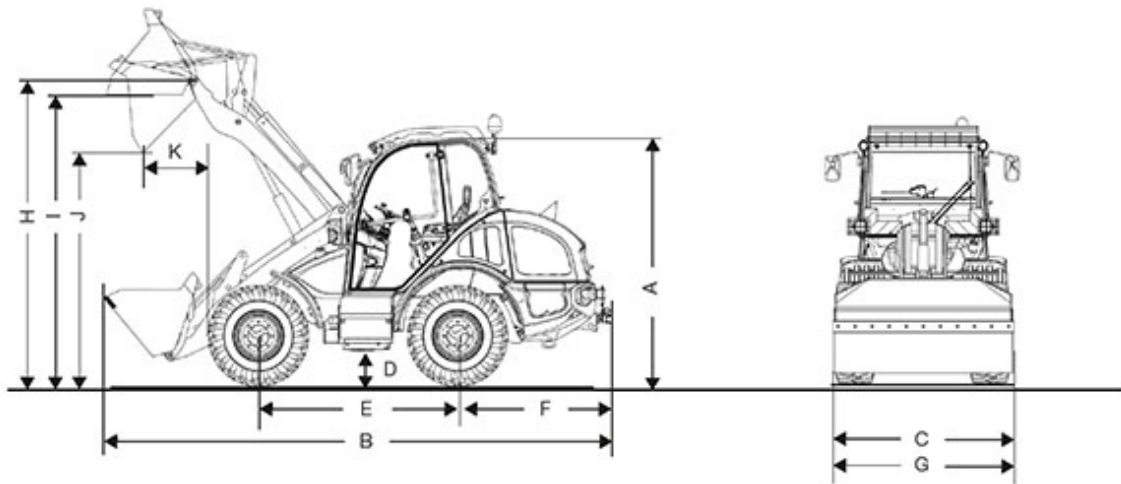

A	Height	2.480 mm
B	Length	5.410 mm
C	Width	1.720 mm
D	Ground clearance	330 mm
E	Wheelbase	2.020 mm
	Center of front axle to tip of teeth	1.900 mm
F	Center of rear axle to end of vehicle	1.490 mm
G	Bucket width	1.950 mm
H	Bucket pivot point	3.290 mm
I	Overhead loading height	3.090 mm



J	Dumping height	2.580 mm
K	Dump reach	650 mm
	Stack height	3.040 mm
	Turning radius (over tyres)	2.840 mm

All information was determined with the following tires: 12.5 – 20

**Please note**

that product availability can vary from country to country. It is possible that information / products may not be available in your country. More detailed information on engine power can be found in the operator's manual; the stated power may vary due to specific operating conditions.

Subject to alterations and errors excepted. Applicable also to illustrations.

Copyright © 2017 Kramer-Werke GmbH.