



DT10

Track Dumpers



Your professional equipment: DT10.

The crawler-mounted dumper DT10 from Wacker Neuson guarantees absolutely safe and comfortable driving thanks to a high level of stability and running smoothness. Also for overcoming curbs, this equipment is your best partner in tight spaces.

- Easy and convenient operation thanks to the fully-hydrostatic drive.
- Robust crawler design, guaranteeing durability and low wear and tear.
- Single-piece engine hood and optimized layout of the servicing points facilitate daily maintenance.
- The rubber chains and the optimum weight distribution reduce the ground pressure and prevent damage to fragile surfaces.
- Ultra-compact dimensions ideal for tight working conditions and passages; large ground clearance.

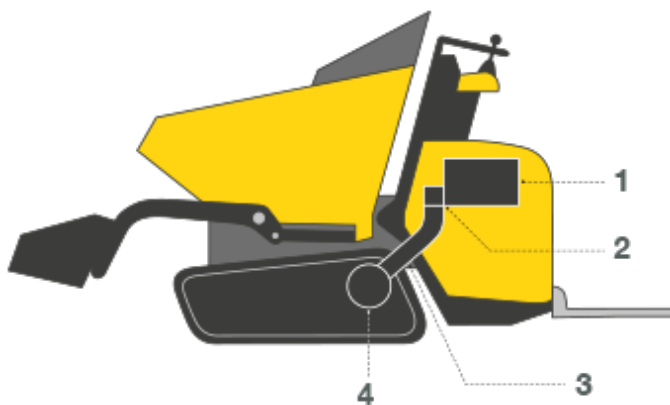

1. Diesel engine
2. Dual variable displacement pump
3. High pressure lines from the pump to the motor
4. Distributor transmission/axle

Hydrostatic drive system

Simply start and off you go: Thanks to the hydrostatic drive system, no frequent gear changing is required and the operator can focus entirely on his work. Ideal for rental parks or frequently changing operators.

- Hydraulically activated, pilot-controlled forward + reverse travel lever for sensitive operation of the DT12, DT15 and DT25
- Two driving positions: optionally sensitive with a high tractive force or fast (not in DT10)
- Hydraulically activated drive system and work hydraulics can be operated independently from each other
- Low service and maintenance costs thanks to the low-wear drive system



**WACKER
NEUSON**
all it takes!



Maintenance

Valuable time can be saved during maintenance and therefore money can also be saved. The better and faster the access to the hydraulics or engine are, the faster the machine is back in application.

- Good service access in order to safely take care of daily control procedures
- Quick access to the maintenance points
- High degree of safety due to the lockable engine hood

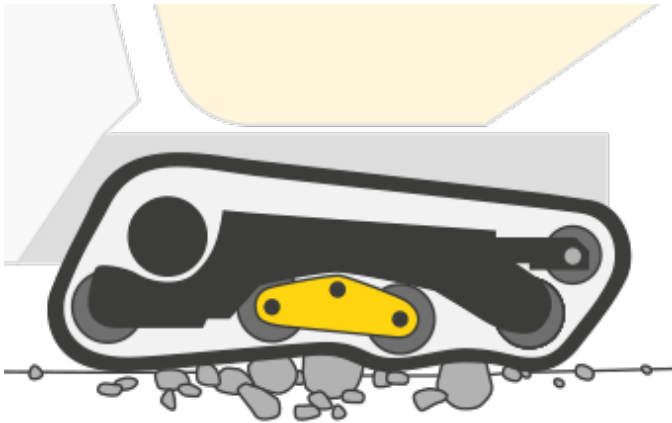

Always constant propulsion,

because the suspension-mounted rollers adapt to any terrain.



Technical specifications

	Front tip skip	High tip skip	Front tip skip platform	Swivel tip skip
Operating data				
Shipping weight kg	630	740	590	775
Shipping weight SLE kg	695	820		
Payload max. kg	1,000	550	1,000	1,000
Skip capacity leveled l	367	240	300	431
Skip capacity heaped l	427	280	210	460
L x W x H mm	1823 x 830 x 1280	1684 x 830 x 1280	1882 x 806 x 1280	1960 x 700 x 1280
Engine / Motor				
Engine performance Diesel kW	9.7	9.7	9.7	9.7
at rpm rpm	3,600	3,600	3,600	3,600
Travel speed km/h	4	4	4	4
Gradeability %	36	36	36	36
Fuel tank capacity l	9.7	9.7	9.7	9.7



Dimensions

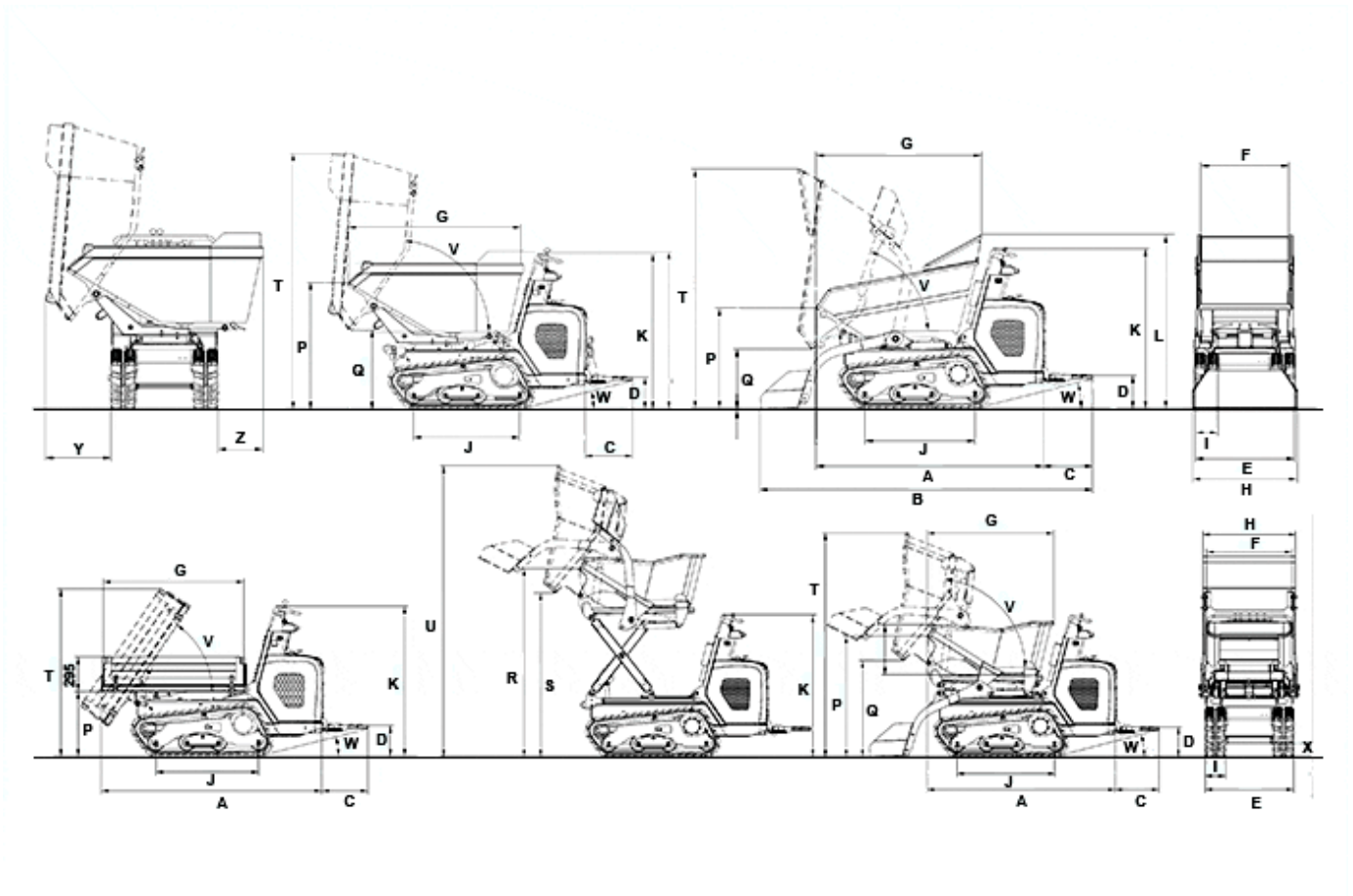

		Front tip skip	High tip skip	Swivel tip skip	Front tip skip platform
A	Length (without running board)	1,800 mm	1,684 mm	1,960 mm	1,882 mm
B	Length with self-loading system (without running board)	2,267 mm	2,240 mm		
C	Length running board	393 mm	393 mm	393 mm	393 mm
D	Height above running board	265 mm	265 mm	265 mm	265 mm
E	Width undercarriage	790 mm	790 mm	790 mm	790 mm
F	Skip width	700 mm	764 mm	730 mm	806 mm
G	Skip length	1,320 mm	1,134 mm	1,427 mm	1,200 mm
H	Width with self-loading system	830 mm	830 mm		



I	Chain width	180 mm	180 mm	180 mm	180 mm
J	Length track rise	875 mm	875 mm	875 mm	875 mm
K	Height over control console	1,280 mm	1,280 mm	1,280 mm	1,280 mm
L	Height	1,365 mm		1,301 mm	
P	Height of skip front edge	804 mm	1,076 mm	1,045 mm	849 mm
Q	Dump height max.	474 mm	868 mm	650 mm	256 mm
R	Height		1,688 mm		
S	Dump height max.		1,467 mm		
T	Height skip raised	1,905 mm	2,009 mm	2,112 mm	1,430 mm
U	Height		2,610 mm		
V	Dump angle	70 °	82 °	85 °	56 °
W	Bucket rollback running board	14 °	14 °	14 °	14 °
X	Ground clearance	172 mm	160 mm	172 mm	160 mm
Y	Dumping distance	487 mm			
Z	Rear overhang	337 mm			

Please note

that product availability can vary from country to country. It is possible that information / products may not be available in your country. More detailed information on engine power can be found in the operator's manual; the stated power may vary due to specific operating conditions. Subject to alterations and errors excepted. Applicable also to illustrations.
Copyright © 2017 Wacker Neuson SE.